



C O N T R O L M A N U A L



Close control units

CARRIER CCU Controller

CONTENTS	PAGE
1 - GENERAL INFORMATION	2
2 - COMPOSITION	3
2.1 On the front:	3
2.2 On the rear:	4
3 - MENU TREE	7
4 - ACCESS LEVEL (menu 8)	10
5 - CONFIGURING THE NUMBER OF UNITS	11
6 - CONFIGURING THE UNIT	12
6.1 Unit parameters	12
6.2 Humidifier parameters (visible if P10=2)	18
6.3 Supply air fan parameters (visible if P05=1 or 2 or 3)	20
7 - FAULT LEVEL (menu 6)	21
8 - WEEKLY PROGRAMMING (menu 5)	22
8.1 Ventilation on sub-menu 5.1	22
8.2 Shifting the temperature setpoints (sub-menu 5.2)	22
8.3 Using the weekly programming	22
9 - CONTROL	22
10 - SENSORS	23
11 - COMMISSIONING	24
11.1 Operating status of masters / slaves units	24
11.2 Operating information for each unit (menu 1 "operating info")	24
11.3 Tables of alarms	25
12 - BUS FOR MASTER/SLAVE FUNCTION	27
12.1 Bus connection	27
12.2 Addressing procedure for the units	27
13 - BUS FOR CONNECTION TO AN RS485 MODBUS CMS	28
13.1 Bus connection between the units and the CMS	28
13.2 Configuring the communication bus parameters (menu 7)	29
13.3 Modbus Protocol	29
14 - BUS FOR CONNECTION TO A CMS (LON)	32
14.1 Bus connection between the controllers, gateway and the CMS	33
14.2 Configuration of the connectors linked to the LON gateway.	34
14.3 List of parameters	35

1 - GENERAL INFORMATION

The **CCU CONTROLLER** is fitted as standard to Close Control Unit systems. Setting and display console equipped with a 160-character LCD screen. The **CCU CONTROLLER** is equipped with a microprocessor and an expansion board to provide the following functions:

- **Filtration**

Checking the pressure drop in the filters, by monitoring the air flow and fouling level.

- **Control function (Cooling Mode)**

- **Chilled water model:**

Gradual opening of the three-way valve following an increase in temperature.

- **Direct expansion model:**

Triggering of one or more refrigerating stages following an increase in temperature. (Action on condensation unit).

- **Control function (Heating Mode)**

- **Hot water coil model:**

Gradual opening of the three-way valve following a decrease in temperature.

- **Electric heater model:**

Triggering of one or two stages following a decrease in temperature.

- **Control function (Dehumidification Mode)**

- Opening of a chilled water valve or triggering of refrigerating stages, following an increase in humidity.

- Triggering of heating mode if there is a drift in temperature.

- As an option, decrease in the air flow to increase the latent part of the cooling capacity.

- **Control function (Humidification Mode)**

- Triggering of humidification following a decrease in humidity.

- **Fan control**

- Management of operation and faults for a 1-speed fan or variable speed control fan.

- Fan on/off via an outer contact, internal timer.

- Variation of speed by regulation of temperature, or of hygrometry, or pressure in false floor, or in constant flow rate.

- Time-limited fan delay for an electric heater.

- Interlock the controls and controllers to operation of the fan.

- Shift in start-up, if there are several units at the same site.

- Soft start of the ventilation if there is a variable air volume.

- **Safety and alarms**

- Overheating thermostat (Manual reset) on the electric heater.

- Pressure sensor for checking the air flow and filter fouling (Thresholds interlocked to the variation in the air flow).

- Configurable alarm threshold for high and low temperature.

- Configurable alarm threshold for high and low humidity.

- Low supply air temperature limitation sensor (limitation of the cooling capacity).

- Water leak sensor.

- **Configurable potential-free (dry) contacts made available for:**

- Critical fault summary: air flow, fan, compressors, clogged filter, temperature sensor.

- Non-critical fault summary: filter fouled, electric heater, humidifier, water leak, target temperatures exceeded, target relative humidity exceeded.

- **Memorisation**

- Storage of the last 20 faults with the date and time of each fault, plus the readings of all the analogue input values at the time of the fault.

- Parameter setting storage in the event of a power failure.

- **Remote control**

- Option of remote control.

- **Metering**

- Option to display metering for:

- The number of operating hours for the fans, compressors, electric heater stages, the humidifier, the fault summaries sent with individual reset of each meter.

- The number of the compressor start-ups.

2 - COMPOSITION

THE CCU CONTROLLER COMPRISES:

2.1 On the front:

- A human-machine interface used to carry out adjustments, and signal and display the various states and information
The display appears on a backlit LCD (4 lines x 40 characters).

DESCRIPTION OF THE FRONT PANEL:

- 1 - Starting up (green LED)
- 2 - "Power on" indicator (yellow LED)
- 3 - Fault signal indicator (red LED)
- 4 - Reset
- 5 - Cursor pad
- 6 - Number pad
- 7 - Validation
- 8 - Correction
- 9 - Setpoints values
- 10 - 160-character LCD screen

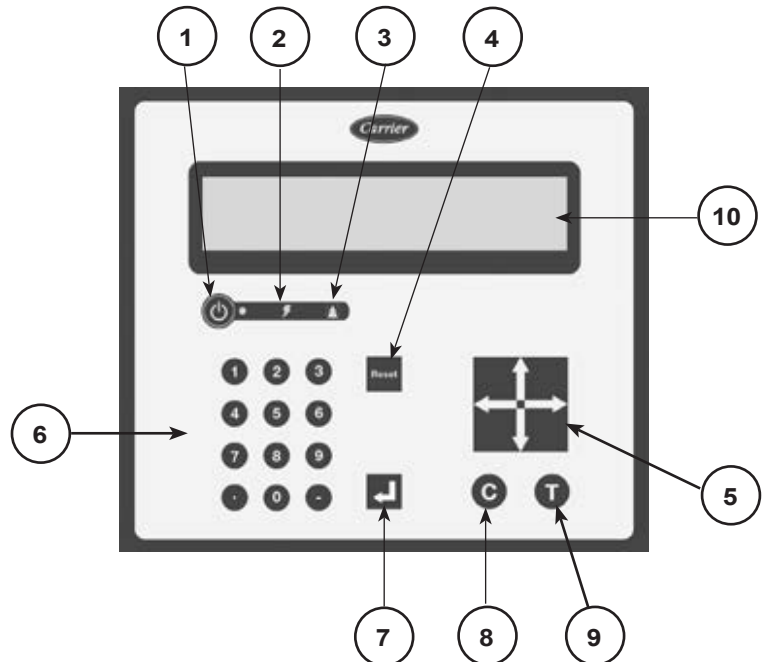

The dialogue between the machines and the user is provided by simple, precise text messages on a 160-character LCD screen. The CCU CONTROLLER automatically displays information on the operation of the unit.

(Example⇒Appearance of a fault).

It comprises:

- A backlit crystal screen with 4 lines of 40 characters.
- A forced off or on authorisation push button, equipped with LED indication (green LED).
 - Green LED off → unit off.
 - Green LED flashing → remote control open.
 - Green LED permanently on → unit on
- A voltage on indicator (yellow LED).
- A fault signal indicator (red LED).
- A "RESET" push button for resetting the faults.
- An "ENTER" push button to confirm (modification of a value).
- A push button to delete the last digit displayed when modifying values.
- A push button "T" to quickly modify the setpoints for the unit being queried "heating, cooling, humidification, dehumidification" or to quickly modify the trigger setpoint for the extra unit.
- A cursor pad.
- A number pad.

The user can configure or query the machines at any time via a tree menu, the first window for which comprises the following sections

```

MON 10/04/2017 09H30 SYSTEME C.CCU
CNFIGURATION OF NUMBER OF UNITS
UIT 1 : IN AUTOMATIC MODE
UIT 2 : STOPPED
    
```

Note: The text that follows the unit number indicates its operating status.

The first line is simply a display of the date and time. We can access this main menu via the "0" number key from any of the displays.

Move the cursor opposite the line corresponding to the required information using the cursor pad, then hit "ENTER".

The "CONFIGURATION OF NUMBER OF UNITS" line is used to configure the operation of the units connected to the bus.

The "UNIT..." lines are used to query the machine.

To return to the main menu, press the number key "0" several times.

• Locking the keypad

The control can be locked or unlocked by pressing the "right arrow" and "left arrow" keys simultaneously for 5 seconds. When the controller is locked, the user can view the information but cannot edit the settings.

2.2 On the rear:

The various connectors used to connect the various elements required to control the unit.

• INPUTS

On/off:

- Acquisition of states via the traditional electro-mechanical components.

Analogue:

- Acquisition of temperatures via a thermistor type sensor.
- Acquisition of relative humidities via sensors delivering a voltage varying from 0 to 10 V for relative humidity of 0 to 100%.
- Acquisition of the differential pressure of air on the filter by means of a sensor delivering a voltage varying from 0 to 10V or from 0.5 to 4.5V for 0 to 1000Pa.
- Acquisition of the differential pressure of air on the fan (allowing the calculation of the flow rate) by means of a sensor delivering a voltage varying from 0 to 10V for 0 to 2500Pa

• OUTPUTS

On/off:

- Fan control.
- Stage control of compressors and electric coils.
- Critical and non-critical fault summary changeover contacts.

Analogue:

- Control of the three-way valves for the water coils and the electric heater current valve.
- Control of the progressive humidifier.
- Control of the fan speed controller.

LOCATION OF TERMINALS (main board)

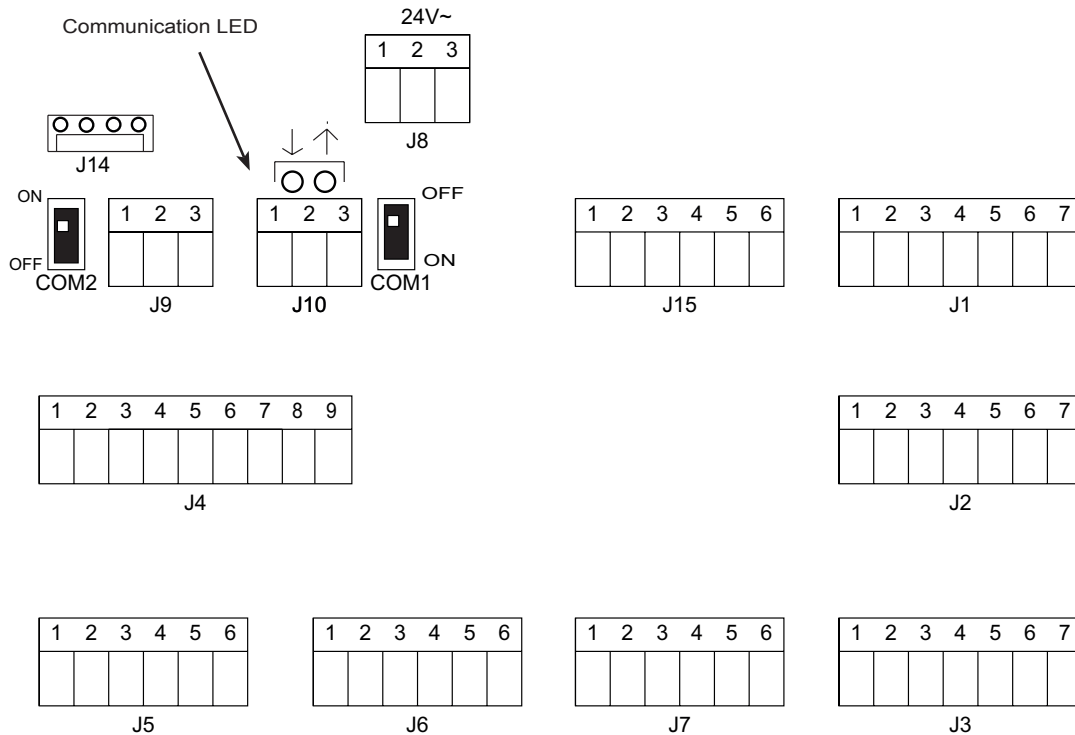

● Designation of terminals

- EA = Analogue inputs
- EL = Logic inputs
- SA = Analogue outputs
- SL = Logic outputs

TERMINAL		CCU Controller
J1 (EA)	1	Target temperature sensor (10 K Ω)
	2	0 V
	3	Supply air limit temperature sensor (10 K Ω)
	4	Target relative humidity sensor (0 - 10 V)
	5	0 V
	6	Sensor for controlling the differential pressure on the filter (0-10 V or 0.5 - 4.5 V)
	7	+12 V
J2 (EL)	1	Remote control
	2	Fire detection/External safety
	3	Supply air fan operation feedback
	4	Electric heater safety thermostat with manual reset
	5	Humidifier fault or maintenance
	6	Water leak
	7	Logic input common terminal
J3 (EL)	1	Summary of condensation unit 1 faults
	2	Temperature setpoint shift
	3	Summary of condensation unit 2 faults
	4	Hot water coil or electric heater
	6	Summer or winter mode
	7	Logic input common terminal
	J4 (SA)	1
2		0 V
3		Chilled water coil 3-way valve.or mixed coil
4		Progressive humidifier
5		0 V
6		Variation of the air flow rate
7		Free cooling damper
8		0 V
9		Electric heater (TRIAC)
J5 (SL)	1	Critical fault summary common terminal
	2	Standby contact if P206=0 (or active if P206=1) in the summary of major faults
	3	Active contact if P206=0 (or standby if P206=1) in the summary of major faults
	4	Non-critical fault summary common terminal
	5	Standby contact if P205=0 (or standby if P205=1) in the summary of minor faults
	6	Active contact if P205=0 (or standby if P205=1) in the summary of minor faults

TERMINAL		CCU Controller
J6 (SL)	1	Condensation unit 1 control
	2	
	3	Refrigerating stage no. 1 common terminal
	4	Condensation unit 2 control
	5	
	6	Refrigerating stage no. 2 common terminal
J7 (SL)	1	Control of electric heater stage 1
	2	Control of electric heater stage 2
	3	Electric heater control common terminal
	4	Supply air fan control
	5	Not used
	6	Fan control common terminal
J8	1	24 V AC power supply
	2	24 V AC power supply
	3	0 V
J9	1	RS485 A or + (Link between controllers for master/slave function)
	2	RS485 B or - (Link between controllers for master/slave function)
	3	0 V
J10	1	RS485 A or + (Link with CMS or gateway)
	2	RS485 B or - (Link with CMS or gateway)
	3	0 V
J14	1	+ 12 V
	2	RS485 A or + (Link with CPY humidifier and/or FMA)
	3	RS485 B or - (Link with CPY humidifier and/or FMA)
	4	0 V
J15 (SA)	1	0 V
	2	Outdoor temperature sensor (10 K Ω)
	3	Outdoor relative humidity sensor (0- 10 V)
	4	Raised floor differential pressure monitoring sensor (0- 10 V)
	5	Fan differential pressure sensor (0-10V)
	6	5 V

COM SWITCH

- COM 1: Line termination resistance on CMS link (see section 13)
- COM 2: BUS polarisation on master/slave link (see section 12)

3 - MENU TREE

Depending on the configuration, only the menus in use are displayed.

```

MON 10/04/2017 09:30 CCU.C SYSTEM
CONFIGURATION OF NUMBER OF UNITS
UNIT 1: IN AUTOMATIC MODE
UNIT 2: STOPPED
    
```

With the cursor opposite the "CONFIGURATION OF NUMBER OF UNITS" line, press the Enter key to access the following menus:



Configuration of number of units

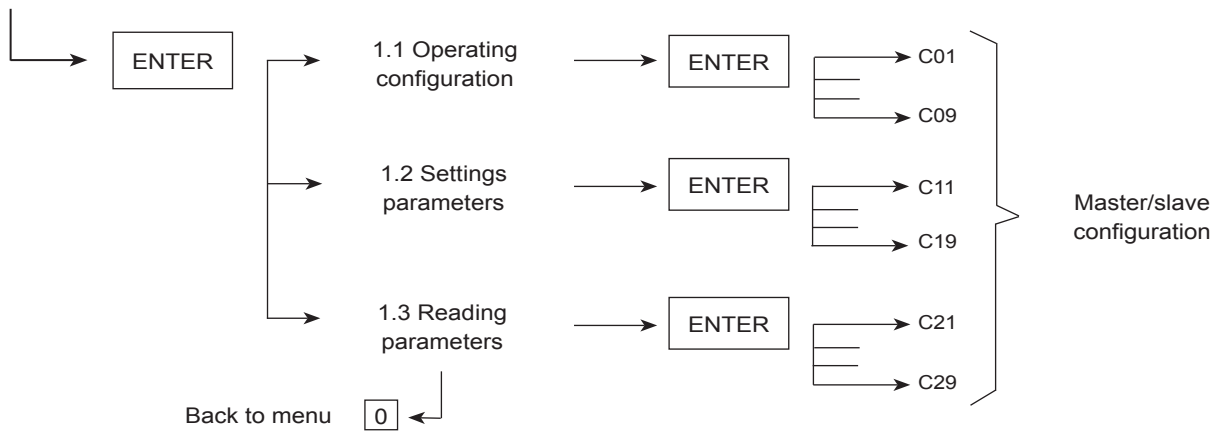

```

MON 10/04/2017 09H30 C.CCU SYSTEM
CONFIGURATION OF NUMBER OF UNITS
UNIT 1: IN AUTOMATIC MODE
UNIT 2: STOPPED
    
```

With the cursor opposite the "UNIT 1" line, press the Enter key to access the following menus:

Unit 1

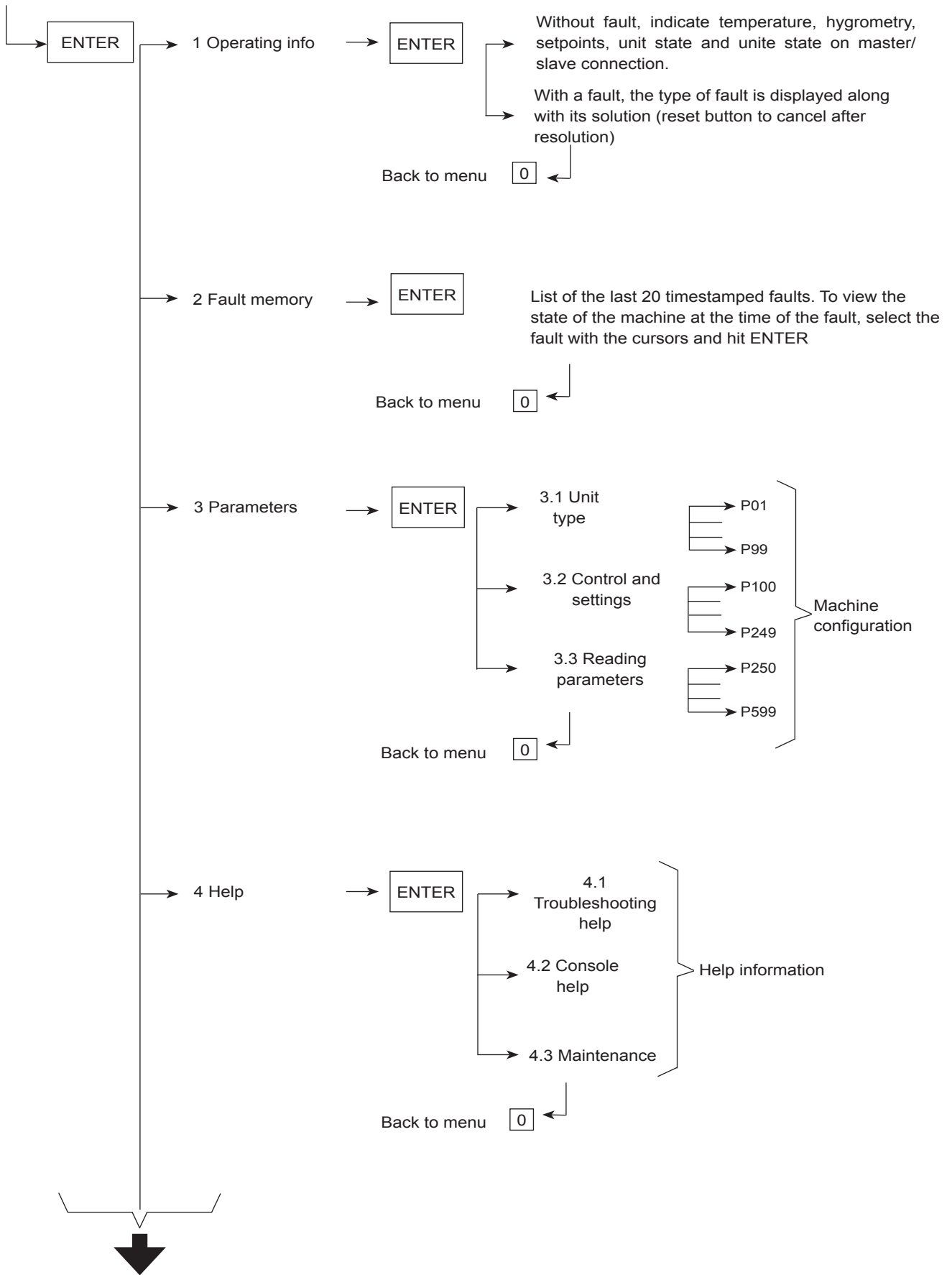

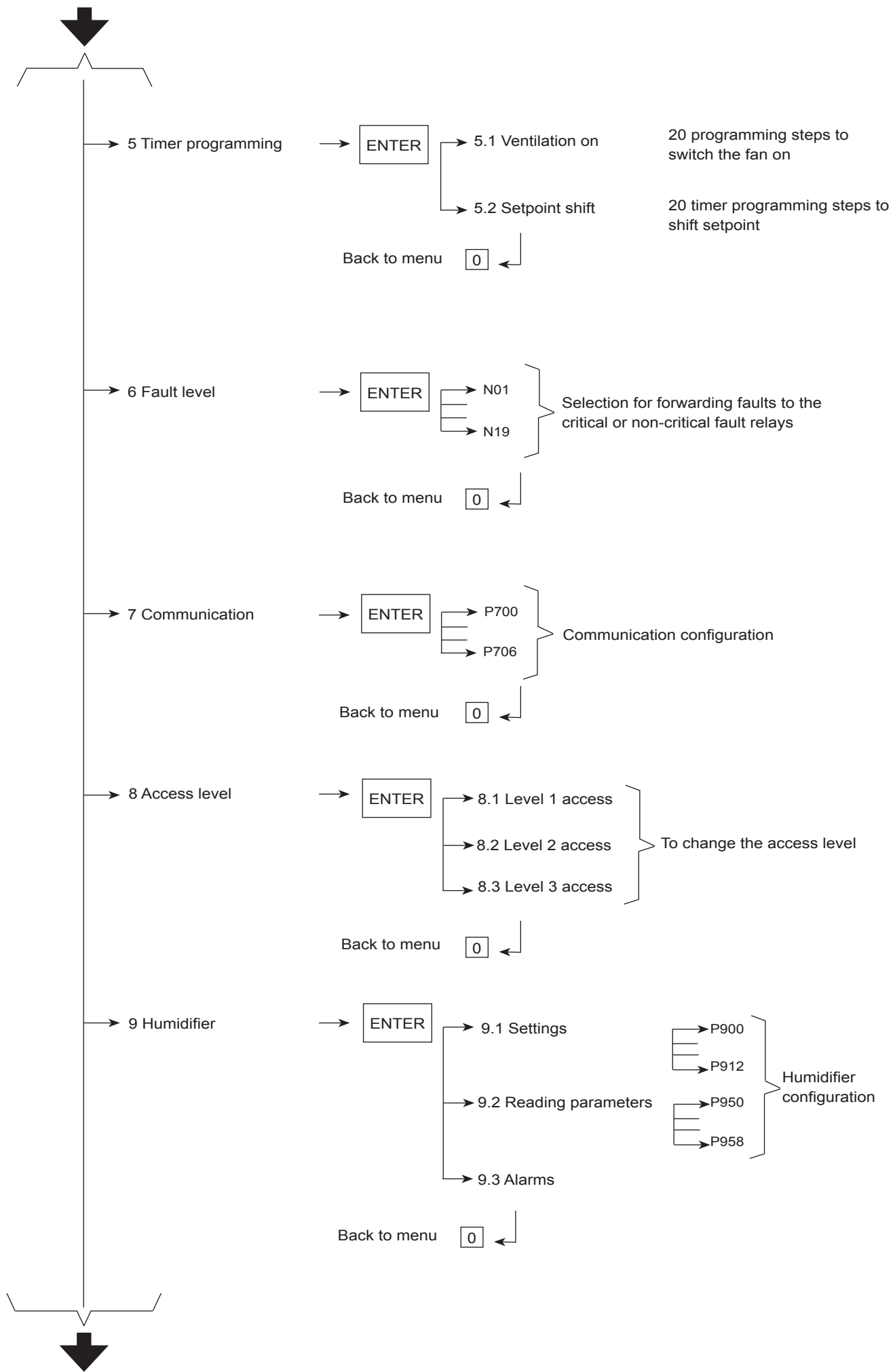

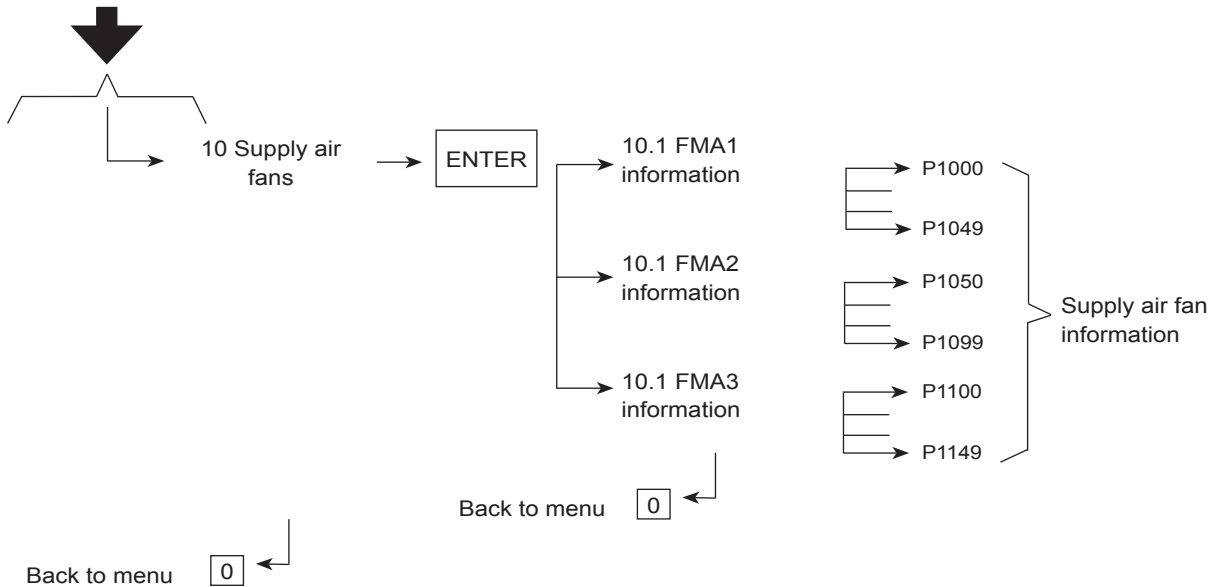

4 - ACCESS LEVEL (menu 8)

The CCU CONTROLLER has 3 access levels, two of which require an access code. The various levels are accessed using menu 8 in the unit's menu.

- Access to level 1 (No access code)

This is a general level designed for the end user. This level gives access to all the reading parameters and the settings for the main setpoints and proportional bands:

- Cooling
- Heating
- Humidification
- Dehumidification
- Supply air temperature limits
- Temperature and humidity limit thresholds
- Filter check.

It also allows the language, date and time to be altered.

- Access to level 2 (editable numeric code)

This level is designed for installers and experienced users. It gives access to the following functionalities:

- Free cooling
- On/off control and configuration lock
- Fixed shifts during heating/cooling
- Limits relating to the supply air fan speed variation
- Time delay settings
- CMS communication parameter settings

- Access to level 3 (uneditable numeric code)

This level is designed for the manufacturer's operators and for factory settings. It gives access to all parameters of the control.

5 - CONFIGURING THE NUMBER OF UNITS



These parameters are only visible if parameter P215 = 1 (master unit)

This sub-menu groups together the operating parameters for the units. They can operate individually or grouped as master/slaves.

Access level	No.	Description	Setting	By default	Display condition
OPERATING CONFIGURATION					
2	C01	Number of units	1 to 32: self-contained units 2 to 10: in master/slave	1	
2	C02	Additional unit	0: No additional unit 1: One additional unit	0	C01 > 1 and C01 < 11
2	C03	Backup unit	0: No backup unit 1: One backup unit	0	C01 > 1 and C01 < 11 and C02 = 0
2	C04	Additional backup unit	0: No additional backup unit 1: One additional backup unit	0	C01 > 2 and C01 < 11 and C02 = 1
2	C05	Rotation	0: No rotation (the last unit is the backup unit). 1: Automatic rotation (according to the time delay adjustable using C12). 2: Periodic restart (According to the parameters C13 to C16).	0	C02 = 1 or C03 = 1
2	C08	Language used	0: French 1: English 2: German 3: Spanish	0	
2	C09	Locking of the configuration	0: Unlocked (the adjusted master/slave functions are not activated) 1: Locked (the adjusted master/slave functions are activated).	0	
SETTING					
2	C11	Setpoint for activating the additional unit (authorisation setpoint)	15 to 40°C (but always 2 K greater than the highest of the P103 cooling setpoints for the units currently operating)	27°C	C02 = 1
2	C12	Unit rotation time delay	Value adjustable from 0 to 240 h (value '0' is used for testing and corresponds to a period of 5 minutes)	168 h	C05 = 1
2	C13	Numbers of days between 2 periodic restarts	Adjustable value from 0 to 60 days (The value 0 is used for the tests and corresponds in 5mn between 2 relaunchings)	30j	C05 = 2
2	C14	Periodic restart time	Hours / Minutes (This setting is not taken into account if parameter C13 = 0)	8H00	C05 = 2
2	C15	Periodic restart duration	5 to 300mn	30mn	C05 = 2
2	C16	Cooling setpoint shift during periodic restart	0 to 5 °C	3 °C	C05 = 2
READ-ONLY					
1	C21	Unit rotation counter	Note: This counter counts down in increments and when it reaches 0, it is reset to the value for C12 and the unit whose number precedes the stopped unit or units stops in turn. The unit whose number precedes those currently operating starts.		C05 = 1
1	C22	Additional unit setpoint (calculated setpoint)	Note: This gives the actual value of the setpoint, i.e. at least 2 K above the highest cooling setpoint for all units		C02 = 1
1	C23	Number of days before periodic relaunching	Note: this meter décrémente every day at 00:00 am and when it arrives at 0, the unity(unit) in sleep mode starts at the hour(o'clock) settled(adjusted) to C14	j	C05 = 2
1	C24	Time before the end of periodic restart	Note: this meter shows the time staying before the end of the periodic relaunching	mn	C05 = 2
1	C29	Software version number			

TREE FOR CONFIGURING THE NUMBER OF UNITS
(only visible if parameter P215 = 1 "master unit")

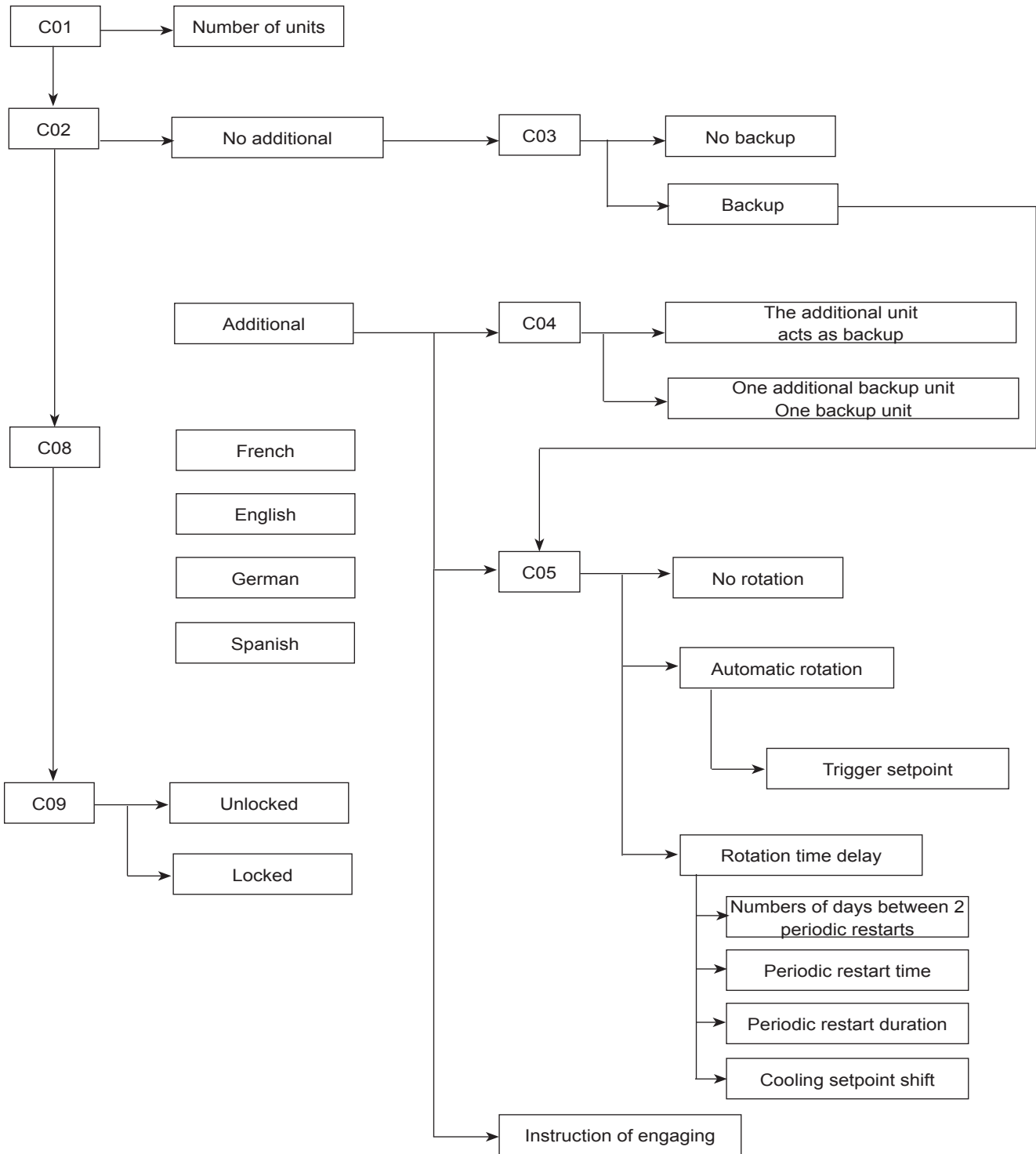

6 - CONFIGURING THE UNIT

6.1 Unit parameters

6.1.1 UNIT TYPE (sub-menu 3.1)

To limit the amount of different software required whilst meeting our customers' need for applications, the CCU CONTROLLER is provided with a configuration system. It allows the composition of the unit to be configured, along with all the functions which must be managed by the system

To configure the CCU CONTROLLER, use the menu No.3: PARAMETER and the sub-menu No. 3.1: UNIT TYPE. (Menu on CCU CONTROLLER display)

These parameters are directly linked to the composition of the unit, and they must not be modified on site.

The procedure for saving these parameters is carried out in the workshop. (To view the type of programming specific to your control, refer to the configuration guide attached to the unit).

To modify parameters P01 to P99, the unit must be stopped and the configuration unlocked. Parameter P99 (Locking of configuration) is equipped with a system which counts the number of times the configuration is unlocked.

Most of the parameters can only be modified if the correct authorisation level is accessed in Menu No.8 of the CCU CONTROLLER (See paragraph 4 in this guide).

Access level	No.	Description	Setting	By default	Display condition
CONFIGURATION OF THE FANS					
2	1	On control	1: Outer contact (the push button on the console acts as a forced stop) 2: Internal timer (the push button on the console acts as priority forced stop and the outer contact as forced start)	1	
3	2	Number of speeds or variation of air flow rate	1: One speed 10: Variation of the rotation speed with increase of the speed via an increase in cooling control. 11: Variation of the rotation speed with increase of the speed via an increase in heating control. 12: Variation of the rotation speed via cooling and heating control. 13: Variation of the rotation speed with decrease of the speed via an increase in dehumidification control. 14: Manual variation of the fan rotation speed. 15: Variation of the rotation speed with pressure increase on the raised floor. 16: Variation of the rotation speed depending on the temperature difference (return/supply air) 17: Variation for constant flow rate control	14	P05 = 0 P07 > 0 P08 > 0 P07 > 0 and P08 > 0 P09 > 0 P03 = 2 et P05 > 0
3	3	Machine model	1: 50CJ configuration 2: 50CO configuration	1	
3	5	FMA control	0: On/off or gradual 0-10 V 1: 1 MODBUS gradual FMA 2: 2 MODBUS gradual FMA 3: 3 MODBUS gradual FMA	0	
CONTROL SELECTION					
3	6	Limit via the supply air temperature	0: No limitation 1: With limitation (Low limit affecting cooling control, high limit affecting heating control)	0	P11 ≠ 0
3	7	Cooling control	0: No cooling control 1: One chilled water coil 2: One direct expansion system	0	
3	8	Heating control	0: No heating control 1: One hot water coil 2: One electric heater 3: Electric heater or hot water coil via contact	0	
3	9	Dehumidification control	0: No dehumidification control 1: One chilled water coil 2: One direct expansion system	0	
3	10	Humidification control	0: No humidification control 2: Progressive MODBUS	0	
3	11	Free cooling control	0 = Without 1 = With	0	P07 > 0
CONFIGURATION OF THE EXCHANGERS					
3	16	Electric heater control	1: One on/off output (one stage) 2: Two on/off outputs (three stages) 3: One progressive stage 4: One progressive stage and one on/off stage	1	P08 = 2 or 3
3	17	Direct expansion system control	5: Control of a staged condensation unit, with external management of automatic systems and unit faults. 6: Control of two condensation units with 1 stage, with external management of automatic systems and unit faults	=1	P07 = 2 to 4 or P09 = 2 to 4
3	18	Humidifier type	1: 3 kg/h 230 V 2: 3 kg/h 400 V 3: 8 kg/h 400 V 4: 15 kg/h 400 V	1	P10 = 2
3	19	Type of water coil	1: One mixed coil (cooling/heating operation via contact) 2: Two self-contained coils (one cooling coil, one heating coil)	2	P07 = 1 and P08 = 1 or 3

MODE SELECTION

2	31	Cooling setpoint offset	0: No control 1: Set offset shifted up by outer contact 2: Set offset shifted up by internal timer	0	P07 > 0
2	32	Heating setpoint offset	0: No shift 1: Set offset shifted down by outer contact 2: Set offset shifted down by internal timer	0	P08 > 0
3	35	Differential pressure measurement	0: Via 0-10 V pressure sensor 1: Via 0.5 - 4.5 V pressure sensor	0	
3	37	Controlled temperature sensor type	0: Return sensor fitted 1: Remote room sensor	0	P07>0 or P08>0

AIR FLOW RATE

3	40	Max air flow rate	4000 to 13300m ³ /h 4000 to 27000m ³ /h 4000 to 40000m ³ /h	13300m ³ /h 27000m ³ /h 40000m ³ /h	P02 = 17 and P05 = 1 P02 = 17 and P05 = 2 P02 = 17 and P05 = 3
---	----	-------------------	--	--	--

FMA DIALOGUE CONFIGURATION

3	71	FMA1 configuration (*)	0: Not completed 1: Completed	0	P05 = 1 or 2 or 3
3	72	FMA2 configuration (*)	0: Not completed 1: Completed	0	P05 = 2 or 3
3	73	FMA3 configuration (*)	0: Not completed 1: Completed	0	P05 = 3

LOCKING

2	99	Locking of the configuration	0: Configuration unlocked (The unit cannot be started up; the unit type parameters may be changed). 1: Configuration locked (The unit can be started up by pressing the "On/Off" push button on the console. The unit type parameters may no longer be modified. The number of times the configuration is unlocked is counted.)	0	
---	----	------------------------------	--	---	--



(*) When these parameters are modified, a sequence is launched to configure the FMAs.

6.1.2 CONTROL AND SETTINGS (sub-menu 3.2)

Access level	No.	Description	Setting	By default	Display condition
1	100	Language used	0: French 1: English 2: German 3: Spanish	0	
1	101	Date	Day/Month/Year		
1	102	Time	Hours/Minutes		
COOLING CONTROL					
1	103	Temperature setpoint in cooling mode	8.0 to 45.0°C if P08 = 0 MAX (10, P106) to 45°C if P08 > 0	25.0°C	P07 > 0
1	104	Proportional band temperature in cooling mode	1.0 to 10.0 K	2.0 K	P07 > 0
1	105	Integral time temperature in cooling mode	0 min 0 s to 30 min 0 s (0 to 1800 s)	0 min 0 s	P07 > 0
HEATING CONTROL					
1	106	Temperature setpoint in heating mode	10.0 to 35.0°C 10.0 to MIN (35.0, P103)°C	20.0°C	P08 > 0
1	107	Proportional band Temperature in heating mode	1.0 to 10.0 K	2.0 K	P08 > 0
1	108	Integral time Temperature in heating mode	0 min 0 s to 30 min 0 s (0 to 1800 s)	0 min 0 s	P08 > 0

DEHUMIDIFICATION CONTROL					
1	109	Humidity setpoint during dehumidification	20 to 90% if P10 = 0 MAX (20, P115) to 90% if P10 > 0	60%	P09 > 0
1	110	Humidity proportional band in dehumidification mode	5 to 30%	10%	P09 > 0
1	111	Humidity integral time in dehumidification mode	0 min 0 s to 30 min 0 s (0 to 1800 s)	0 min 0 s	P09 > 0
HUMIDIFICATION CONTROL					
1	115	Humidity setpoint during humidification	20 to 90% if P09 = 0 MAX (20, P109) to 90% if P09 > 0	40%	P10 > 0
1	116	Humidity proportional band in humidification mode	5 to 30%	10%	P10 > 0
1	117	Humidity integral time in humidification mode	0 min 0 s to 30 min 0 s (0 to 1800 s)	0 min 0 s	P10 > 0
RETURN TEMPERATURE LIMITATION					
1	121	Downward shift of the temperature limit	0.0 to 10.0 K	2 K	P06 = 0 and P09 > 0
1	122	Proportional band for reduction of the cooling demand	1.0 to 10 K	2 K	P06 = 0 and P09 > 0
FREE COOLING CONTROL					
2	125	Free cooling activation differential	3 to 20 K	3 K	P11 = 1
2	126	Free cooling activation low limit setpoint	-5 to 20°C	0°C	P11 = 1
2	128	Free cooling opening limit	0 to 100%	100 %	P11 = 1
2	129	External weight in water low limit setpoint	0 to 15 g	4 g	P11 = 1 and (P09 > 0 or P10 > 0)
2	130	External weight in water high limit setpoint	8 to 18 g	12 g	P11 = 1 and (P09 > 0 or P10 > 0)
LIMITATION OF THE SUPPLY AIR TEMPERATURE					
1	140	Low limit setpoint	5 to 30 °C	14°C	P06 = 1 and (P07 > 0 or P09 > 0)
1	141	Proportional band for the low limit	1 to 20 K	4 K	P06 = 1 and (P07 > 0 or P09 > 0)
1	142	High limit setpoint	30 at 60°C	50°C	P06 = 1 and P08 > 0
1	143	Proportional band for the high limit	1 to 20 K	4 K	P06 = 1 and P08 > 0
TEMPERATURE SETPOINT SHIFT					
2	144	Cooling setpoint offset	0 to 30 K	5 K	P31 > 0
2	145	Heating setpoint offset	0 to 20 K	5 K	P32 > 0
AIR FLOW RATE					
2	146	Air flow rate setpoint	4000 to (P40)m³/h	10000m³/h	P02 = 17
2	147	Flow rate proportional band	100 to 50000m³/h	50000m³/h	P02 = 17
2	148	Air flow rate integral time	0 to 1800s	30s	P02 = 17
2	149	Air flow rate derivation time	0 to 1800s	0s	P02 = 17
FLOOR PRESSURE					
2	150	Discharge pressure setpoint	20 to 250 Pa	100 Pa	P2 = 15
2	151	Discharge pressure proportional band	20 to 1000 Pa	50 Pa	P2 = 15
2	152	Discharge pressure integral time	0 min 0 s to 30 min 0 s (0 to 1800 s)	3 min 0 s	P2 = 15
2	153	Discharge pressure derivative time	0 min 0 s to 30 min 0 s (0 to 1800 s)	3 min 0 s	P2 = 15
LIMITATION OF THE FAN ROTATION VARIABLE SPEED CONTROL					
2	155	Percentage of the rotation speed	P156 to P157	(P156+P157)/2	
2	156	Minimum percentage of the rotation speed	0 to 90% if P08 = 0 or 1 and P10 = 0 50 to 90% if P08 > 1 or P10 > 0	60%	P02 > 9
2	157	Maximum percentage of the rotation speed	P156 to 100%	100 %	P02 > 9
2	158	Percentage of proportional bands reserved for controlling just the valves	0 to 100%	50 %	P02 = 10 to 13

RETURN/SUPPLY AIR TEMPERATURE CONTROL					
2	159	Return/supply air temperature differential setpoint	5.0 to 20.0°C	10.0°C	P2 = 16
2	160	Return/supply air temperature proportional band	1.0 to 10.0°C	2.0°C	P2 = 16
CHECK THE FILTERS					
The values correspond to the unit's maximum air flow. If there is a variation in the fan speed, these values are reduced proportionally					
1	161	Air flow presence detection differential pressure setpoint	10 to 80 Pa	30 Pa	P02 ≠ 17
1	162	Filter fouling detection differential pressure setpoint	60 to 500 Pa	150 Pa	
1	163	Blocked filter detection differential pressure setpoint	100 to 550 Pa	190 Pa	
AIR FLOW CONTROL					
2	164	Air flow rate low limit	0 to MIN(P146, 10000)	4000m³/h	P02 = 17
COMPRESSOR VALIDATION					
3	181	Validation of compressor circuit 1	0: compressor stopped 1: compressor authorised	1	P17 = 1 to 16
3	182	Validation of compressor circuit 2	0: compressor stopped 1: compressor authorised	1	P17 = 3.4 or 6
TIME DELAY					
2	185	Warm-up at fan start-up (validation of detection of T° and RH exceeded)	5 to 180 min	30 min	
2	186	Application of control at fan start-up	10 to 180 s	30 s	
2	188	Fault taken into account when temperature or relative humidity exceeded	1 to 5 min	2 min	
2	190	Post-ventilation of electric heater	1 to 300 min	10 min	P08 = 2 or 3
2	191	Delayed fan control after operation request	0 to 480 s	0 s	
2	192	Duration of fan soft start incline	0 to 500 s	30 s	P02 > 9
2	193	Refrigerating circuit rotation time delay	0 to 240 h	240 h	P17 = 3, 4 or 6
CHECKING WHETHER TEMPERATURE THRESHOLDS ARE EXCEEDED					
1	200	Temperature upper limit threshold	30 to 75°C if P07 = 0 (P103 + P104) to 75°C if P07 > 0	40°C	P07 or P08 > 0
1	201	Temperature low limit threshold	30 to 75°C if P08 = 0 5°C to (P106 - P107) if P08 > 0	10°C	P07 or P08 > 0
CHECKING WHETHER HUMIDITY THRESHOLDS ARE EXCEEDED					
1	202	Humidity upper limit threshold	40 to 100% RH if P09 = 0 (P109 + P110) to 100% RH if P09 > 0	80% RH	P09 or P10 > 0
1	203	Humidity low limit threshold	10 to 40% RH if P10 = 0 10% RH to (P115 - 116) of P10 > 0	20% RH	P09 or P10 > 0
TEST MODE					
3	204	Test mode	0: no 1: yes	0	P17 > 0
FAULT RELAY					
1	205	Minor fault relay direction of action	0: standard standby/active contacts 1: reversed standby/active contacts	1	
1	206	Major fault relay direction of action	0: standard standby/active contacts 1: reversed standby/active contacts		
SELECTION OF THE ORIGIN OF THE REGULATED TEMPERATURE					
2	207	Controlled temperature origin	0 : Probe connected to the controller 1 : Value received by modbus	0	P07 > 0 ou P08 > 0
2	208	Time before switch to controller sensor when value not received by Modbus	5 to 180 s	30s	(P07 > 0 ou P08 > 0) et P207 = 1
MASTER/SLAVE BUS					
2	215	Unit number on console	1 to 32	1	

6.1.3 Reading parameters (sub-menu 3.3)

This third sub-menu gives access to all the values (temperatures, relative humidities, pressures, time delays, meters, input and output states, etc.) managed by the **CCU CONTROLLER**. Only the useful parameters are displayed. They cannot be modified. The meters can be reset to zero. To do this, place the cursor on the chosen meter and simultaneously press the Reset and 0 keys for 5 to 6 seconds.

All these parameters are accessible from the "customer" access level.

Access level	No.	Description	Unit	Display condition
CALCULATED SETPOINT				
1	250	Cooling setpoint value	°C	P07 > 0
1	251	Temperature setpoint value in heating mode	°C	P08 > 0
1	252	Air flow activation threshold value	Pa	P02 ≠ 17
1	253	Filter fouling activation threshold value	Pa	
1	254	Filter clogging activation threshold value	Pa	
MEASURED VALUE				
1	255	Target temperature	°C	P07 > 0 or P08 > 0
1	256	Target relative humidity	%	P09 > 0 or P10 > 0
1	257	Filter differential pressure	Pa	
1	258	Outdoor temperature	°C	P11 = 1
1	259	Supply air temperature	°C	P06 = 1
1	265	Outdoor humidity	%	P03 = 2 and (P09 > 0 or P10 > 0) and P11 = 1
1	266	Raised floor differential pressure	Pa	P2 = 16
1	267	Differential pressure fan 1	Pa	P02 = 17
1	268	External weight in water	g/Kg	(P09>0 or P10>0) and P11=1
1	269	Air flow rate	m³/h	P02 = 17
LOGIC INPUT STATE (ON/OFF)				
1	270	Electric heater safety thermostat with manual reset	default = off	
1	271	Summary of condensation unit 1 faults	default = on	P17 > 5
1	272	Summary of condensation unit 2 faults	default = on	P17 > 6
1	278	External safety contact		
1	279	On request contact		
1	281	Humidifier maintenance, fault or operation feedback	default = off	P10 = 1
1	282	Fan operation feedback	default = off	
1	284	Water leak contact	default = off	
1	287	Hot water coil or electric heater selection contact	Electric on off Hot water on	P08 = 3
1	288	Summer or winter mode contact	Summer on off Winter on	P19 = 1
PERCENTAGE FOR ANALOGUE OUTPUTS				
1	290	Opening of the heating coil three-way valve or electric heater percentage Opening of the heating coil three-way valve	%	P04 = 0 and (P08 = 1 or (P08 = 2 and (P16 = 3 or P16 = 4)) P04 = 1 and (P08 = 1 or P08 = 3)
1	291	Opening of the cooling coil three-way valve	%	(P07 = 1 or 3) or (P09 = 1 or 3)
1	294	Progressive humidifier percentage	%	P10 = 1
1	295	Fan rotation speed	%	P02 > 9
1	296	Fresh air percentage	%	P11 = 1
1	297	Electric heater percentage	%	P04 = 1 and ((P08 = 2 or P08 = 3) and (P16 = 3 or P16 = 4))
STATE OF THE COMPRESSOR CONTROLS				
	300	Condensation unit 1		
	301	Short-cycle protection time countdown for condensation unit 1		
	302	Condensation unit 1 number of start-ups		
	303	Condensation unit 1 operating-hour meter		
	304	Condensation unit 2		
	305	Short-cycle protection time countdown for condensation unit 2		
	306	Condensation unit 2 number of start-ups		
	307	Condensation unit 2 operating-hour meter		

STATE OF THE ELECTRIC HEATER CONTROLS				
1	320	Electric heater stage 1	Off/On	P16 = 2
1	321	Operating-hour meter for electric heater stage 1	h	P16 = 2
1	322	Electric heater stage 2	Off/On	P16 = 2 or 4
1	323	Operating-hour meter for electric heater stage 2	h	P16 = 2 or 4
STATE OF THE FAN CONTROLS				
1	330	Fan control state	Off/On	
1	331	Fan operating-hour meter	h	
STATE OF THE FAULT SUMMARY CONTROLS				
1	350	Indication of the critical faults	Off/On	
1	351	Operating-hour meter indicating the critical faults	h	
1	352	Indication of the non-critical faults	Off/On	
1	353	Operating-hour meter indicating the non-critical faults	h	
STATE OF THE FAN CONTROLS				
1	360	Fan on request	Off/On	P01 = 2
1	361	Temperature setpoint shift request	Off/On	P31 = 2 or P32 = 2
TIME DELAY COUNTDOWN				
1	362	Warm-up	mins	
1	363	Activation time delay for the compressor stages	mins	P17 = 3 or 4
VERSION NUMBER				
1	365	CCU CONTROLLER software version number		
TEMPERATURE FOR REGULATION				
1	370	Measured temperature	°C	P207 = 1
1	371	Temperature received for control by modbus	°C	P207 = 1
ORDER NUMBER				
1	570	SO order number		
1	571	OF number		

6.2 Humidifier parameters (visible if P10=2)

6.2.1 Settings (sub-menu 9.1)

Access level	No.	Description	Setting	By default	Display condition
3	900	Maximum production	20 to 100%	100 %	P10 = 2
3	901	Off delay time	0 s to 120 s	0 s	P10 = 2
3	902	Water conductivity (0 = automatic measurement > 0 = forced conductivity)	0 to 125 µS/cm	0 µS/cm	P10 = 2
3	903	Conductivity pre-alarm threshold	0 to 2000 µS/cm	1500 µS/cm	P10 = 2
3	904	Conductivity alarm threshold	0 to 2000 µS/cm	2000 µS/cm	P10 = 2
3	905	Foam detection threshold control (0 = foam detection excluded 1 = max. foam detection sensitivity 100 = min. foam detection sensitivity)	0 to 100%	50 %	P10 = 2
3	906	Internal conductivity control of the cylinder on warm-up as compared to the nominal (less than 100%: conductivity increases)	50 to 200%	100 %	P10 = 2

Access level	No.	Description	Setting	By default	Display condition
3	907	Control of the duration of release for dilution	50 to 200%	100 %	P10 = 2
3	908	Cylinder maintenance limit time (0 = "CY" cylinder life and maintenance alarm no longer appears as a matter of course)	0 h to 4000 h	3000 h	P10 = 2
3	909	Limit time between two periodic releases	1 h to 240 h	24 h	P10 = 2
3	910	Days of inactivity awaiting release	1 to 199 days	3 days	P10 = 2
2	911	Manual drain	0: without 1: with		P10 = 2
2	912	Prewashing	0: without 1: with		P10 = 2

6.2.2 Reading parameters (sub-menu 9.2)

Access level	No.	Description	Unit	Display condition
1	950	Outdoor request display	%	P10 = 2
1	951	Display of the instantaneous steam flow rate (instantaneous steam)	kg/h	P10 = 2
1	952	Conductivity of supply water	µS/cm	P10 = 2
1	953	Current consumed	A	P10 = 2
1	954	Maximum production display (corresponding to the configured P900 value)	kg/h	P10 = 2
1	955	Nominal steam production	kg/h	P10 = 2
1	956	Cylinder hours counter (can be reset to 0 by pressing the reset+0 keys for 5 secs)	h	P10 = 2
1	957	Machine hours counter (cannot be reset to zero; read only)	h	P10 = 2
1	958	Humidifier state 0: Not activated 1: Evaporation cycle start 2: Charging with water 3: Evaporating 4: AFS drain 5: Water drain (for dilution or manual) 6: Water drain ended 7: Complete drain for extended period of inactivity 8: Network or manually requested complete drain 9: Water shortage management 10: Prewash 11: Periodic drain		P10 = 2

6.2.3 Alarm (sub-menu 9.3)

Alarm	Description
	The humidifier has no fault
Mn	Replace the cylinder
EC	Water conductivity too high
E1	Configuration parameter error
E0	Internal memory error
EH	Electrode overcurrent
EP	Low steam flow rate during reduced production
EU	Water level raised without humidification request
EF	Lack of supply water
ED	Drain problem



To acknowledge a humidifier fault, go into the "ALARM" menu (menu 9.3) and press the "Reset" key

6.3 Supply air fan parameters (visible if P05=1 or 2 or 3)

6.3.1 FMA1 information (sub-menu 10.1)

Access level	No.	Description	Unit	Display condition
1	1000	FMA1 max. speed	rpm	P05 = 1, 2 or 3
1	1001	FMA1 requested speed	rpm	P05 = 1, 2 or 3
1	1002	FMA1 current speed	rpm	P05 = 1, 2 or 3
1	1003	FMA1 current consumed	A	P05 = 1, 2 or 3
1	1004	FMA1 peak supply voltage	V	P05 = 1, 2 or 3
1	1005	FMA1 power input	W	P05 = 1, 2 or 3
1	1010	FMA1 fault summary	Off/On	P05 = 1, 2 or 3
1	1011	FMA1 start-up fault	Off/On	P05 = 1, 2 or 3
1	1012	FMA1 rotation direction fault	Off/On	P05 = 1, 2 or 3
1	1013	FMA1 current limitation	Off/On	P05 = 1, 2 or 3
1	1014	FMA1 temperature limitation	Off/On	P05 = 1, 2 or 3
1	1015	FMA1 off	Off/On	P05 = 1, 2 or 3
1	1020	FMA1 internal DC voltage	V	P05 = 1, 2 or 3
1	1021	FMA1 IGBT temperature	°C	P05 = 1, 2 or 3
1	1022	FMA1 indoor room temperature	°C	P05 = 1, 2 or 3
1	1023	FMA1 MCU temperature	°C	P05 = 1, 2 or 3
1	1024	FMA1 motor temperature	°C	P05 = 1, 2 or 3
1	1048	FMA1 product code		P05 = 1, 2 or 3
1	1049	FMA1 software version		P05 = 1, 2 or 3

6.3.2 FMA2 information (sub-menu 10.2)

Access level	No.	Description	Unit	Display condition
1	1050	FMA2 max. speed	rpm	P05 = 2 or 3
1	1051	FMA2 requested speed	rpm	P05 = 2 or 3
1	1052	FMA2 current speed	rpm	P05 = 2 or 3
1	1053	FMA2 current consumed	A	P05 = 2 or 3
1	1054	FMA2 peak supply voltage	V	P05 = 2 or 3
1	1055	FMA2 power input	W	P05 = 2 or 3
1	1060	FMA2 fault summary	Off/On	P05 = 2 or 3
1	1061	FMA2 start-up fault	Off/On	P05 = 2 or 3
1	1062	FMA2 rotation direction fault	Off/On	P05 = 2 or 3
1	1063	FMA2 current limitation	Off/On	P05 = 2 or 3
1	1064	FMA2 temperature limitation	Off/On	P05 = 2 or 3
1	1065	FMA2 off	Off/On	P05 = 2 or 3
1	1070	FMA2 internal DC voltage	V	P05 = 2 or 3
1	1071	FMA2 IGBT temperature	°C	P05 = 2 or 3
1	1072	FMA2 indoor room temperature	°C	P05 = 2 or 3
1	1073	FMA2 MCU temperature	°C	P05 = 2 or 3
1	1074	FMA2 motor temperature	°C	P05 = 2 or 3
1	1098	FMA2 product code		P05 = 2 or 3
1	1099	FMA2 software version		P05 = 2 or 3

6.3.3 FMA3 information (sub-menu 10.3)

Access level	No.	Description	By default	Display condition
1	1100	FMA3 max. speed	rpm	P05 = 3
1	1101	FMA3 requested speed	rpm	P05 = 3
1	1102	FMA3 current speed	rpm	P05 = 3
1	1103	FMA3 current consumed	A	P05 = 3
1	1104	FMA3 peak supply voltage	V	P05 = 3
1	1105	FMA3 power input	W	P05 = 3
1	1110	FMA3 fault summary	Off/On	P05 = 3
1	1111	FMA3 start-up fault	Off/On	P05 = 3
1	1112	FMA3 rotation direction fault	Off/On	P05 = 3
1	1113	FMA3 current limitation	Off/On	P05 = 3
1	1114	FMA3 temperature limitation	Off/On	P05 = 3
1	1115	FMA3 off	Off/On	P05 = 3
1	1120	FMA3 internal DC voltage	V	P05 = 3
1	1121	FMA3 IGBT temperature	°C	P05 = 3
1	1122	FMA3 indoor room temperature	°C	P05 = 3
1	1123	FMA3 MCU temperature	°C	P05 = 3
1	1124	FMA3 motor temperature	°C	P05 = 3
1	1148	FMA3 product code		P05 = 3
1	1149	FMA3 software version		P05 = 3

7 - FAULT LEVEL (menu 6)

Each type of fault can be forwarded to one of the following two changeover contact relays:

- Non-critical fault relay.
- Critical fault relay.

This menu is used to configure which type of fault will be forwarded to which relay (critical or non-critical).

No.	Description	Setting	Unit	Display condition
N02	No air flow (*)	0: Non-critical fault 1: Critical fault	1	
N03	Fan (*)	0: Non-critical fault 1: Critical fault	1	
N04	(Condensation unit Low pressure for each circuit High pressure or circuit breaking for each circuit)	0: Non-critical fault 1: Critical fault	1	P17 > 0
N05	Filtration fouled	0: Non-critical fault 1: Critical fault	0	
N06	Filtration blocked (*)	0: Non-critical fault 1: Critical fault	1	
N07	Temperature sensors	0: Non-critical fault 1: Critical fault	1	
N08	Electric heater	0: Non-critical fault 1: Critical fault	0	P16 > 0
N09	Humidifier	0: Non-critical fault 1: Critical fault	0	P10 > 0
N11	Water leak	0: Non-critical fault 1: Critical fault	0	
N13	Temperature set high	0: Non-critical fault 1: Critical fault	0	P07 > 0 or P08 > 0
N14	Temperature set low	0: Non-critical fault 1: Critical fault	0	P07 > 0 or P08 > 0
N15	Relative humidity set high	0: Non-critical fault 1: Critical fault	0	P09 > 0 or P10 > 0
N16	Relative humidity set low	0: Non-critical fault 1: Critical fault	0	P08 > 0 or P10 > 0

Note:

- The faults marked (*) shut down the machine
- If the master/slave function is used, the faults defined as critical stop the unit.

- Staged for condensation unit control.
- Progressive for the control of the fan speed controller. This slave control exists regardless of the parameter settings.
- Staged for indicating that the upper temperature limit has been exceeded.
- Gradual limitation of the cooling demand if the lower supply air limit setpoint has been exceeded. (Progressive on W, staged on X model).

Depending on the strictly proportional composition of the unit, a discrepancy may remain between the setpoint and the measurement, even with all the elements at 0.

- Heating control

The master control is increased if the temperature drops below the setpoint. This value is broken down according to the parameter settings (unit type parameter) and is:

- Progressive for the electrical current or hot water valve control.
- Progressive for the limitation of the dehumidification control. This slave control exists regardless of the parameter settings.
- Staged for indicating that the lower temperature limit has been exceeded. Depending on the composition of the unit, as strictly proportional, a discrepancy may remain between the setpoint and the measurement, even with all the elements at 0.

- Operation in free cooling mode

W (chilled water) units

- Return air temperature sensor: Progressive operation of motorised dampers then the 3-way valve.
- Supply air temperature sensor: limitation of the 3-way valve then the FRESH AIR damper.

X (direct expansion) units

- Return air temperature sensor: progressive operation of the dampers (condensation units off).
- Supply air temperature sensor: FRESH AIR damper limit

• Control of the "Target" relative humidity

This is proportional or proportional integral.

- Dehumidification control

The master control is increased if the relative humidity exceeds the setpoint. This value is broken down according to the parameter settings (unit type parameter) and is:

- Staged for condensation unit control.
- Progressive for the chilled water valve control.
- Staged for indicating that the upper relative humidity limit has been exceeded.

Depending on the strictly proportional composition of the unit, a discrepancy may remain between the setpoint and the measurement, even with all the elements at 0.

This control is limited by the lower drift of the target temperature.

Note: If the cooling and dehumidification controls control the same component, it is the largest value which counts.

- Humidification control

The master control is increased if the relative humidity drops below the setpoint.

This value is broken down according to the parameter settings (unit type parameter) and is:

- Progressive for the humidifier control.
- Staged for indicating that the lower relative humidity limit has been exceeded.

Depending on the composition of the unit, as strictly proportional, a discrepancy may remain between the setpoint and the measurement, even with all the elements at 0.

10 - SENSORS

• Sensor specifications

• TEMPERATURE

Range: -35°C to + 105°C.

Tolerance: $\pm 0.2^\circ\text{C}$ from 0 to 70°C.

Thermistor: CTN 10 k at 25°C.

Reference: 10 K 3A1.

Adjustment of the controlled and outdoor temperature sensor from -5 to +5 °C (reserved for the manufacturer access level).

• HUMIDITY

0-10 V sensor range

Relative humidity: 0 to 100%.

Adjustment of the controlled and outdoor humidity sensor from -10 to 10 °C (reserved for the manufacturer access level)

• DIFFERENTIAL PRESSURE

Filter differential pressure of P35 = 0 0-10V \rightarrow 0-1000Pa

of P35 = 1 0.5-4.5V \rightarrow 0-1000Pa

Fan differential pressure 0-10V \rightarrow 0-2500Pa

• Failure to connect, wire cut or short circuit feedback.

Only the temperature sensors are controlled.

The fault is displayed. It stops the corresponding controls and controllers, for example: the outdoor sensor fault can stop the free cooling control.

Example of adjustment on controlled temperature:

1. Reading parameters (menu 3.3) \Rightarrow ENTER
2. Cursor opposite parameter P255 - Controlled temperature \Rightarrow ENTER
3. Modify the adjustment (-5 to +5°C)
4. Confirm with the ENTER key.

11 - COMMISSIONING

1. Power up.
2. The yellow voltage present indicator on the console comes on.
3. Adjust the setpoint and settings parameters as explained in sections 4 and 5.
4. Press the power button (if the green LED does not come on, check whether parameter P99 is locked "P99 = 1").
5. The green indicator flashes if the external control contact is open; if the timer is not set to operate the unit then it remains on standby.
6. If the green indicator comes on, the unit will be started.

11.1 Operating status of masters / slaves units

- **Stopped:** The units are operating individually. The unit in question is authorised by the console button and by the external safety contact. The unit is not faulty, it is powered on. The unit is stopped by the on/off control (contact or timer).
- **Forced stop:** The unit in question is stopped by the console button or by the external safety contact. It is not faulty, it is powered on.
- **Operating:** The units are operating individually. The unit in question is authorised by the console button and by the external safety contact. The unit is not faulty, it is powered on. The unit is authorised by the on/off control (contact or timer).
- **In automatic operation:** The units are operating as master/slaves. At least one unit is configured as backup or additional. The unit in question is authorised by the console button and by the external safety contact. The unit is not faulty, it is powered on. The unit is not controlled by the on/off (contact or timer). The unit is not selected as a backup or additional unit.
- **In override:** The units are operating as master/slaves. At least one unit is configured as backup or additional. The unit in question is authorised by the console button and by the external safety contact. The unit is not faulty, it is powered on. The unit is controlled by the on/off (contact or timer).
- **In standby:** The units are operating as master/slaves. At least one unit is configured as backup or additional. The unit in question is authorised by the console button and by the external safety contact. The unit is not faulty, it is powered on. The unit is not controlled by the on/off (contact or timer). The unit is selected as a backup or additional unit, but it is not operating as a backup or additional unit.
- **As backup:** The units are operating as master/slaves. One unit is configured as backup or additional. The unit in question is authorised by the console button and by the external safety contact. The unit is not controlled by the on/off (contact or timer). The unit is selected as a backup or additional unit, it is operating as a backup but not as an additional unit.
- **As additional:** The units are operating as master/slaves. One unit is configured as additional. The unit in question is authorised by the console button and by the external safety contact. The unit is not faulty, it is powered on. The unit is not controlled by the on/off (contact or timer). The unit is selected as an additional unit, it is operating as an additional unit but not as backup.
- **As additional and backup:** The units are operating as master/slaves. One unit is configured as additional. The unit in question is authorised by the console button and by the external safety contact. The unit is not faulty, it is powered on. The unit is not controlled by the on/off (contact or timer). The unit is selected as an additional unit, it is operating as an additional and backup unit.
- **Periodic restart :** The units operate as master / slave. At least one unit is set as backup or supplement. The unit in question is authorized by the button on the HMI and by the external safety contact. The unit is not faulty, and is powered on. The unit is not switched on / off (contact or clock). The unit is chosen as a complement or standby unit and is in periodic restart..
- **With non-critical fault:** The unit in question is powered on. It has at least one non-critical fault, but no critical faults.
- **With critical fault:** The unit in question is powered on. It has at least one critical fault.
- **Powered off:** The CCU CONTROLLER for the unit in question is not responding. It is not powered on or the bus connection is broken.

11.2 Operating information for each unit (menu 1 "operating info")

● Unit with no fault

The first line: displays the values measured by the target relative humidity and/or temperature sensors.

The second line: displays the target relative humidity and/or temperature setpoint values.

For the two values, the value displayed is the setpoint for the last control mode (heating or cooling, humidification or dehumidification).

If the measurement value is below the heating or humidification setpoint, it is this setpoint which is displayed. If the measurement value is above the cooling or dehumidification setpoint, it is this setpoint which is displayed. If the measurement value is between the two setpoints, the value displayed does not change.

The third line displays the unit's operating status:

- **Unit stopped:** The fan is stopped as are all the controls and controllers.
- **Unit operating:** The one-speed or variable speed fan is operating, the controls are authorised, the temperature setpoints are calculated based on the normal value.
- **Unit in fan delay:** The unit stop has been requested, the controls and controllers are no longer authorised. The fan operates until the fan delay is finished.
- **Unit stopped by the safety contact:** The external safety contact is open. The unit stop has been requested.
- **Unit faulty:** the last fault that appeared is displayed with a text indicating the components which have been stopped and the first verifications to be carried out before acknowledging the fault.

11.3 Tables of alarms

Faults	Sources	Causes	Solutions
Filtration fouled	Pressure sensor	Filter fouled	• Clean or replace the filter
Filtration blocked		Filter too dirty (ventilation stopped)	• Replace the filter
No air flow		Belts	• Check the tension • Replace the belts
		Filters	• Clean or replace
		Fan	• See fan fault
		Damper	• Check the opening • Check the servomotor
		Motor	• Check the direction of rotation
	Network	• Check the network pressure drop	
Fan/motor	Belts Switch Circuit breaker Embedded thermistor	Fan stopped	• Check the belts
		Motor	• Check the motor's power supply • Check the switch, the circuit breaker setting, the motor's embedded thermistor • Check the motor cooling • Measure the input current
Electric heater	Electric heater	Overheating	• Check the air flow rate • Measure the input current • Measure the supply voltage • Check the fan delay duration
		No heating	• Check the supply voltage • Check the switches, the circuit breakers, the triac (option), the control component • Reset the thermostat (clear the fault before resetting)
Humidifier	Humidifier	The humidifier does not work	• Check the supply voltage • Check the switch, the circuit breaker, the control component and the humidifier control panel
	Cylinder	Cylinder dirty	Change the cylinder
	No production of steam	No water in the cylinder	• Check the water supply • Check that the valve is operating correctly • Check the power supply to the electrodes • Add a handful of salt to the cylinder • Refer to the indications on the humidifier control panel
	Drain	Pan overflowing	• Check that the drain valve is operating correctly • Check that the drain circuit is not blocked
Condensation unit		Refrigeration stopped	• Refer to the manual or to the unit's controller to troubleshoot the fault
Water leak	Water leak sensor	Pan overflowing	• Check that the siphon is of the correct design • Check the priming of the siphon • Check that the condensate is draining correctly • Check that the air flow is not too high
		Coil or humidifier leak	• Find the leak and stop it
Sensor	Temperature sensor		• Check the sensor • Check the connection and continuity of the cable
No more operation or display		Eprom memory	• Contact CARRIER After-Sales
The time is wrong		Fault with the CPU board battery - the timer has stopped working	• Change the battery



Faults	Sources	Causes	Solutions
Low temperature	Temperature sensor	Sensor	<ul style="list-style-type: none"> • Check the sensor • Replace the sensor
		Malfunction	<ul style="list-style-type: none"> • Check the stability of the control • Check the operation of the heating valve or the electric heater
		Drift in dehumidification mode	<ul style="list-style-type: none"> • Internal load insufficient
High temperature	Temperature sensor	Sensor	<ul style="list-style-type: none"> • Check the sensor • Replace the sensor
		Malfunction	<ul style="list-style-type: none"> • Check the stability of the control • Check the operation of the cooling valve, the compressors
		Room overheated	<ul style="list-style-type: none"> • Revise the room loads
Low humidity	Humidity sensor	Sensor	<ul style="list-style-type: none"> • Check the sensor • Replace the sensor
		Malfunction	<ul style="list-style-type: none"> • Check the stability of the control • Check the operation of the humidifier • Revise the room loads
High humidity	Humidity sensor	Sensor	<ul style="list-style-type: none"> • Check the sensor • Replace the sensor
		Malfunction	<ul style="list-style-type: none"> • Check the stability of the control • Check the operation of the cooling valve, the compressors
		Excessively high humidity	<ul style="list-style-type: none"> • Revise the room loads

12 - BUS FOR MASTER/SLAVE FUNCTION

12.1 Bus connection

BETWEEN THE VARIOUS UNITS

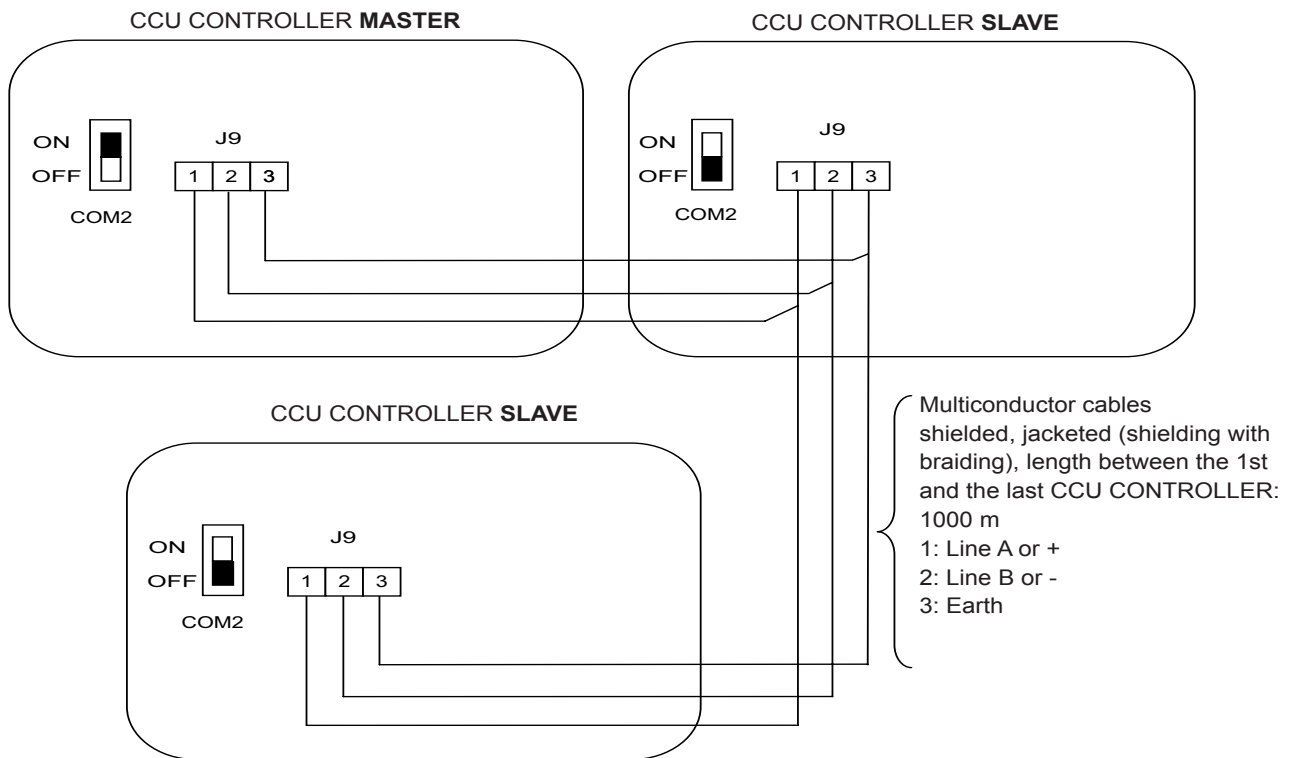

COM2: Bus polarisation switch
 Master unit = ON
 Slave unit = OFF

12.2 Addressing procedure for the units

The first time the power is switched on, all the boards are initialised with the parameter **P215 "UNIT NUMBER ON CONSOLE"** having the value 1.



Connection diagram

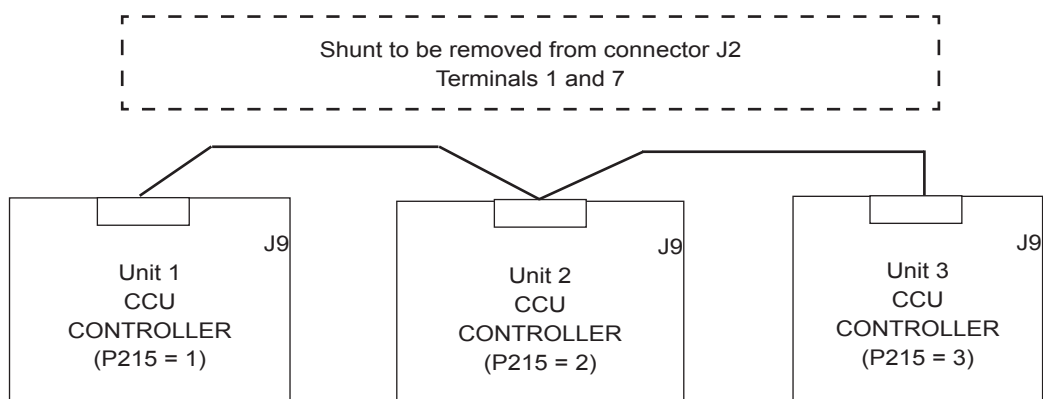

On the controller for unit 1, in the "**CONFIGURATION OF NUMBER OF UNITS**" menu, "**OPERATING CONFIGURATION**", adjust the parameter "**C01 NUMBER OF UNITS**": (3 in the example).

Addressing units

The parameter P215 must be set on each unit.

Position the cursor opposite unit 1 and press the "**ENTER**" key'.

In the "**PARAMETERS**", "**SETTINGS PARAMETERS**" menu, set parameter **P215** to the value corresponding to the unit number.

13 - BUS FOR CONNECTION TO AN RS485 MODBUS CMS

13.1 Bus connection between the units and the CMS

The communication bus between the units and the CMS is a 2-wire RS485 bus

The green light indicates that the data sent by the CMS to the CCU CONTROLLER has been received.
The yellow light indicates that data has been sent by the CCU CONTROLLER to the CMS.

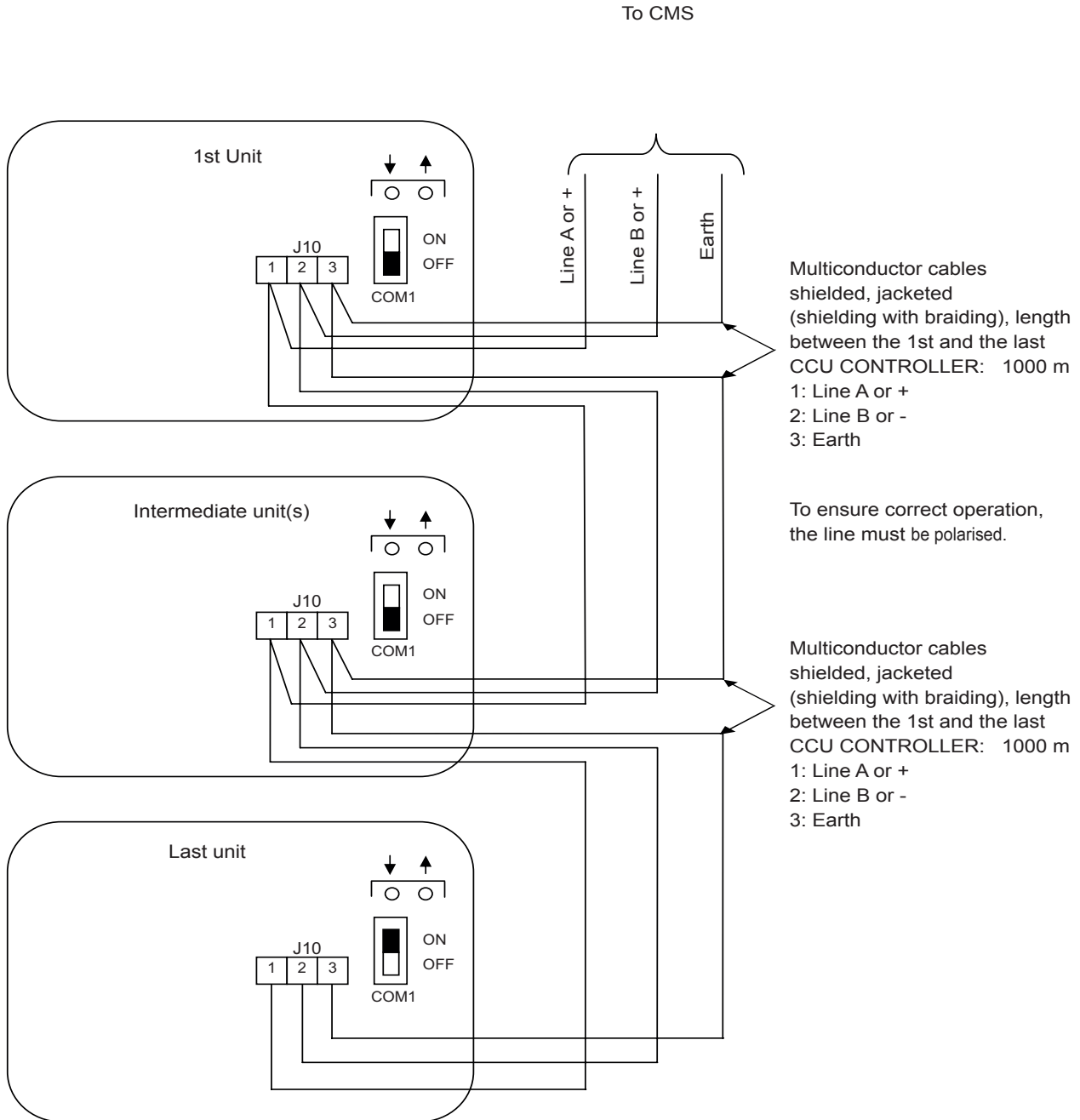

COM1: Line termination resistor switch

First unit = OFF

Intermediate unit = OFF

Last unit = ON

13.2 Configuring the communication bus parameters (menu 7)

This menu gives access to all parameters used to define the communication protocol and the 2-wire RS485 serial link parameters.

Access level	No.	Description	Setting	By default	Display condition
2	700	Communication mode	1: MODBUS/JBUS	1	
2	701	Communication speed	0: 4800 bauds 1: 9600 bauds 2: 19200 bauds	1	
2	702	Parity	0: None 1: Even 2: Odd	0	
2	703	Number of stop bits	1 stop bit 2 stop bits	1	
2	704	Actual number format reversed	0: No 1: Yes	0	
2	705	Slave number	1 to 255	1	
2	706	Control type*	1: Local 2: Remote	1	

* If the selected control type is local, the controller data can be accessed in read only mode by the PLC; with remote selection, the controller data can be accessed in read and write mode by the PLC.

13.3 Modbus Protocol

● RS485 2-wire communication support

3-pin connector (J10)

Terminal 1: A or +

Terminal 2: B or –

Terminal 3: 0 V

Line termination resistor: Connected if COM1 is ON

Not connected if COM1 is OFF

External BUS polarisation.

● Transmission mode

- Series, asynchronous, half duplex, 1 start bit, 8 data bits,
- Parity configured by P702 (none, odd or even)
- Number of stop bits configured by P703 (1 stop bit or 2 stop bits)
- Communication speed configured by P701 (4800, 9600 or 19200)
- Slave no. on the bus configured by P705

● Protocol

- Modbus (Gould Modicon)
- Compatible: JBUS (Merlin Gerin)
- RTU (GENERAL ELECTRIC protocol)

● Codes for functions used

- 1 or 2: Read n bits
- 3 or 4: Read multiple registers (16 bits) Maximum of 126 registers read
- 5: Write one bit
- 6: Write one register
- 8: Read diagnostic counter
- 11: Read event counter
- 15: Write n bits
- 16: Write multiple registers (16 bits)

● Analogue value encoding

- Standard 32-bit IEEE format (2 registers).
- The byte order can be reversed with P704 (0: not reversed or 1: reversed)

Note: the register numbers correspond to the addresses coded on 16 bits.

● Register definitions

- Function 3 or 4 is used for reading,
- Function 6 or 16 is used for writing.

N ° register	Designation	Format	Type	Unit	Min	Max	No setting	Ladder
1	Type of regulator	Decimal	R	43 = CCU Controller				
3 and 4	P258 Outdoor temperature	Float	R					
5 and 6	P255 Controlled temperature	Float	R	°C	-40,0	99,9		1
7 and 8	P256 Controlled humidity	Float	R	% Hr	0	100		1
9 and 10	P250 Calculated cooling temperature setpoint	Float	R	°C	8,0	35,0		
11 and 12	P251 Calculated heating temperature setpoint	Float	R	°C	10,0	35,0		
13 and 14	P265 Outdoor humidity	Float	R	% Hr	0	100		1
15 and 16	P269 Air flow rate	Float	R	m3/h	0	99999		
17 and 18	P370 Measured temperature (J1, 1-2	Float	R	°C	-40,0	99,9		1
19 and 20	P371 Temperature received for control by modbuss	Float	RW	°C	-40,0	99,99	0.1	1
32 and 33	P303 Compressor 1 operating-hour meter	Float	R	h	0	999999		1
34 and 35	P307 Compressor 2 operating-hour meter	Float	R	h	0	999999		1
36 and 37	P321 Electric heater 1 operating-hour meter	Float	R	h	0	999999		1
38 and 39	P323 Electric heater 2 operating-hour meter	Float	R	h	0	999999		1
40 and 41	P331 Fan operating-hour meter	Float	R	h	0	999999		1
48	P290 Heating coil percentage	Decimal	R	%	0	100		1
49	P291 Cooling coil percentage	Decimal	R	%	0	100		1
50	P294 Humidifier percentage	Decimal	R	%	0	100		1
51	P295 Air flow percentage	Decimal	R	%	0	100		1
52	P296 Fresh air percentage	Decimal	R	%	0	100		1
53	P297 Electric heater percentage	Decimal	R	%	0	100		1
257 and 258	P103 Cooling temperature setpoint	Float	RW	°C	8,0	45,0	0,1	1
259 and 260	P106 Heating temperature setpoint	Float	RW	°C	10,0	35,0	0,1	1
261	P109 Humidity setpoint during dehumidification	Decimal	RW	% Hr	20	90	1	1
262	P115 Humidity setpoint during humidification	Decimal	RW	% Hr	20	90	1	1
263 and 264	P144 Fixed setpoint shift in cooling mode	Float	RW	°C	0,0	30,0	0,1	1
265 and 266	P145 Fixed setpoint shift in heating mode	Float	RW	°C	0,0	30,0	0,1	1
300 and 301	P146 Air flow rate setpoint	Float	RW	m3/h	4000	40000	1	1
512	P101 Year	Decimal	RW		0	99	1	1
513	P101 Month	Decimal	RW		1	12	1	1
514	P101 Day of the month	Decimal	RW		1	31	1	
515	P101 day of the week	Decimal	RW	1 : Monday 2 : Tuesday 3 : Wednesday 4 : Thursday 5 : Friday 6 : Saturday 7 : Sunday				
516	P102 Hour	Decimal	RW	h	0	23	1	1
517	P102 Minute	Decimal	RW	mn	0	59	1	1

● **Bit definitions**

- Function 1 or 2 is used for reading,
- Function 5 or 15 is used for writing.

N ° register	Désignation	Format	Type	Unit
1	P706 Control type	Binaire	R	0 = Local 1 = Remote
16	P330 Supply air fan operation	Binaire	R	0 = Arrêt 1 = Marche
17	P300 Compressor 1 operation	Binaire	R	0 = Arrêt 1 = Marche
18	P304 Compressor 2 operation	Binaire	R	0 = Arrêt 1 = Marche
19	P320 Electric heater 1 operation	Binaire	R	0 = Arrêt 1 = Marche
20	P322 Electric heater 2 operation	Binaire	R	0 = Arrêt 1 = Marche
32	P279 Start-up request	Binaire	R	0 = Ouvert 1 = Fermé
33	P287 Contact hot water or electric	Binaire	R	0 = Ouvert 1 = Fermé
34	P288 Summer or winter mode contact	Binaire	R	0 = Ouvert 1 = Fermé
48	P350 Critical fault summary	Binaire	R	0 = Non activé 1 = Activé
49	P352 Non-critical fault summary	Binaire	R	0 = Non activé 1 = Activé
50	Supply air fan fault	Binaire	R	1 = Défaut
51	Air flow fault	Binaire	R	1 = Défaut
52	Filter fouled fault	Binaire	R	1 = Défaut
53	Clogged filter fault	Binaire	R	1 = Défaut
55	Electric heater fault	Binaire	R	1 = Défaut
56	Humidifier fault	Binaire	R	1 = Défaut
57	Water leak fault	Binaire	R	1 = Défaut
58	Condensation unit 1 fault	Binaire	R	1 = Défaut
59	Condensation unit 2 fault	Binaire	R	1 = Défaut
60	High temperature fault	Binaire	R	1 = Défaut
61	Low temperature fault	Binaire	R	1 = Défaut
62	High humidity fault	Binaire	R	1 = Défaut
63	Low humidity fault	Binaire	R	1 = Défaut
64	Controlled temperature sensor fault	Binaire	R	1 = Défaut
65	Output temperature sensor fault	Binaire	R	1 = Défaut
66	Outdoor temperature sensor fault	Binaire	R	1 = Défaut
67	Brine temperature sensor fault	Binaire	R	1 = Défaut
68	EEPROM fault	Binaire	R	1 = Défaut
70	Humidifier board link fault	Binaire	R	1 = Défaut
71	FMA1 link fault	Binaire	R	1 = Défaut
72	FMA2 link fault	Binaire	R	1 = Défaut
73	FMA3 link fault	Binaire	R	1 = Défaut
74	Update fault with the temperature value controlled by Modbus	Binaire	R	1 = Défaut
80	Circuit 1 low pressure fault	Binaire	R	1 = Défaut
81	Circuit 1 high pressure or circuit breaking fault	Binaire	R	1 = Défaut
96	Circuit 2 low pressure fault	Binaire	R	1 = Défaut
97	Circuit 2 high pressure or circuit breaking fault	Binaire	R	1 = Défaut
112	FMA1 fault summary	Binaire	R	1 = Défaut
128	FMA2 fault summary	Binaire	R	1 = Défaut
144	FMA3 fault summary	Binaire	R	1 = Défaut
512	On/Off	Binaire	RW	0 = Arrêt 1 = Marche

14 - BUS FOR CONNECTION TO A CMS (LON)

As an option integrated into the vertical unit, CARRIER provides a MODBUS/LON gateway.

The gateway is used to translate the main information available in MODBUS into LON. (Lists of information available in LON in paragraph 15.3).

It is possible to connect 1 to 5 units to the LON gateway.

This option can also be added to a vertical unit which is already operating.

	RESPONSIBILITY		
	CARRIER	Installer	Integrator
If option "sold separately" /		X	
Checking connection of the gateway RS 485 MODBUS side/		X	
Checking connection of the gateway kit RS 485 - LON side/		X	
CARRIER unit system start-up	(1)	(2)	
			X

(1) CARRIER service if a CARRIER warranty extension (including system start-up) was sold

(2) Installer service if no CARRIER system start-up sold



Note: The MODBUS RS485/LON gateway can only operate correctly if it is connected to a Building Technical Management system (not supplied by CARRIER).

14.1 Bus connection between the controllers, gateway and the CMS

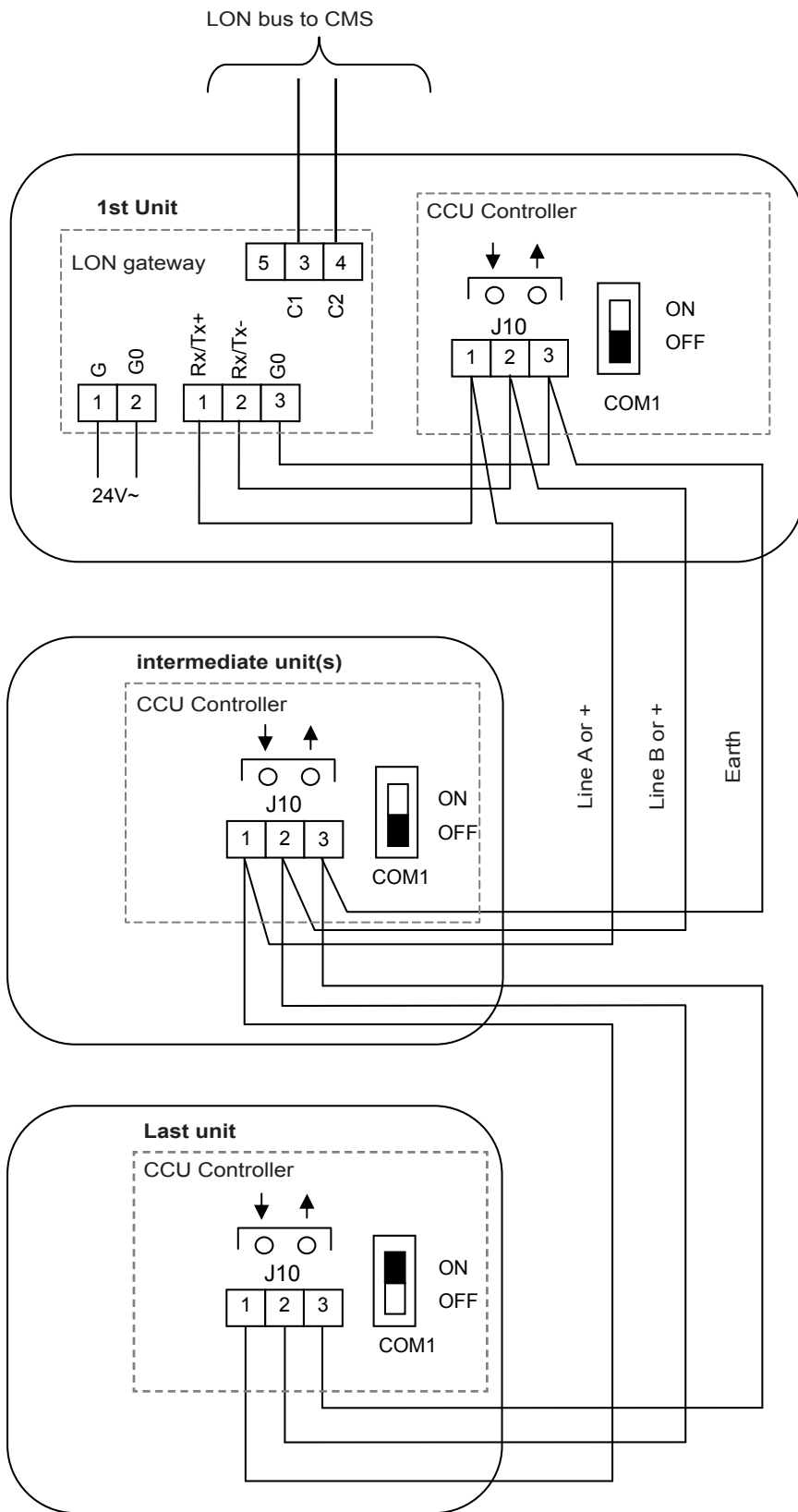

Multiconductor cables shielded, jacketed (shielding with braiding), length between the 1st and the last CCU Controller: 1000 m
 1: Line A or +
 2: Line B or -
 3: Earth



Note: The MODBUS RS485/LON gateway can only operate correctly if it is connected to a Building Technical Management system (not supplied by CARRIER).

14.2 Configuration of the connectors linked to the LON gateway.

The communication parameters for each controller must be set to the following values:

- P700 (Communication mode) = 1 (MODBUS)
- P701 (Communication speed) = 1 (9600 bauds)
- P702 (Parity) = 0 (None)
- P703 (Number of stop bits) = 1 (1 stop bit)
- P704 (Variables in actual format) = 1 (Yes)
- P705 (Bus number) = see information below.
- P706 (Control type = 2 (Remote)

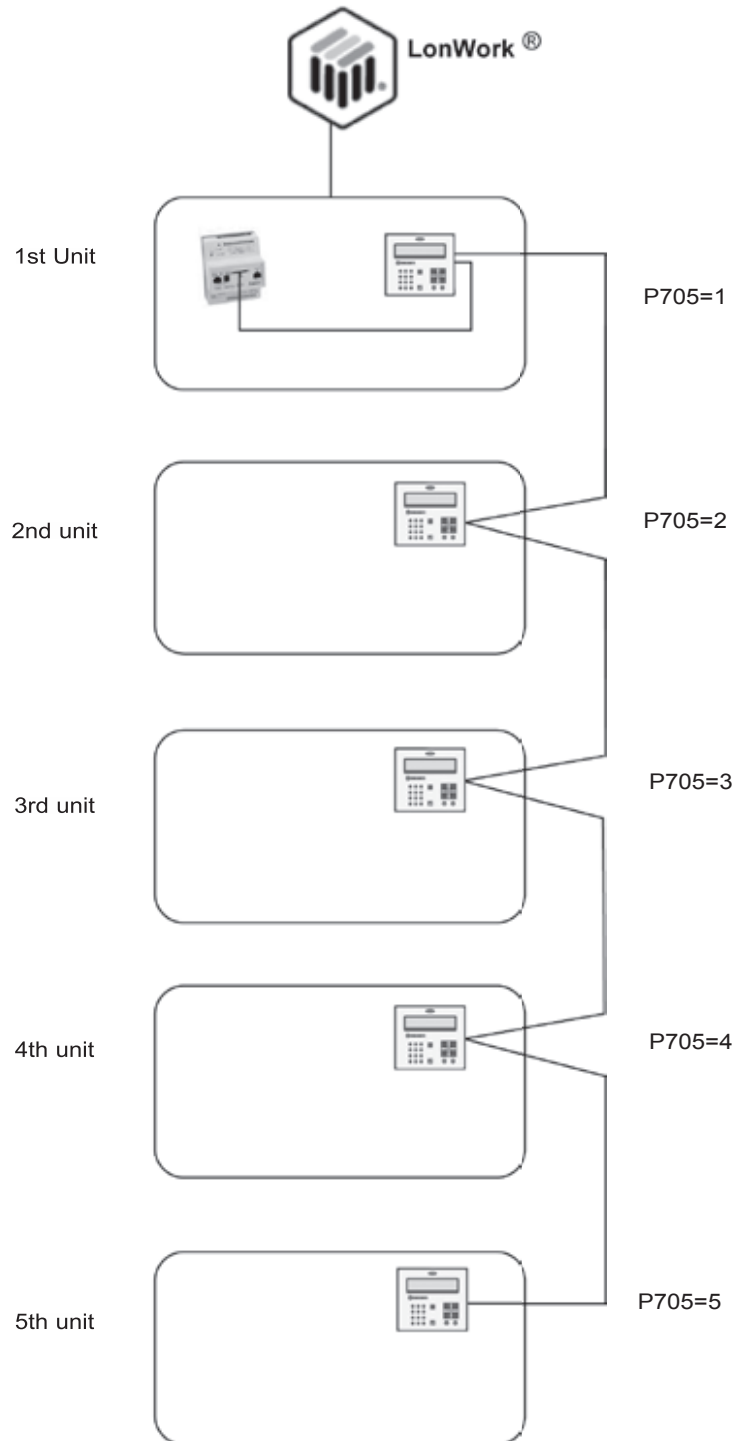

14.3 List of parameters

Description	Name of the LON variable				
	Unit 1	Unit 2	Unit 3	Unit 4	Unit 5
Controlled temperature (P255)	nvo1TempRegulee	nvo2TempRegulee	nvo3TempRegulee	nvo4TempRegulee	nvo5TempRegulee
Controlled humidity (P256)	nvo1HygroRegulee	nvo2HygroRegulee	nvo3HygroRegulee	nvo4HygroRegulee	nvo5HygroRegulee
Supply air temperature (P259)	nvo1TempSouff	nvo2TempSouff	nvo3TempSouff	nvo4TempSouff	nvo5TempSouff
Outdoor temperature (P258)	nvo1OutdoorTemp	nvo2OutdoorTemp	nvo3OutdoorTemp	nvo4OutdoorTemp	nvo5OutdoorTemp
Outdoor humidity (P265)	nvo1OutdoorHygro	nvo2OutdoorHygro	nvo3OutdoorHygro	nvo4OutdoorHygro	nvo5OutdoorHygro
Filter differential pressure (P257)	nvo1PresDifFiltre	nvo2PresDifFiltre	nvo3PresDifFiltre	nvo4PresDifFiltre	nvo5PresDifFiltre
Floor differential pressure (P266)	nvo1PresPlancher	nvo2PresPlancher	nvo3PresPlancher	nvo4PresPlancher	nvo5PresPlancher
Cooling temperature setpoint (P103)	nvo1CoolSetpt	nvo2CoolSetpt	nvo3CoolSetpt	nvo4CoolSetpt	nvo5CoolSetpt
Heating temperature setpoint (P106)	nvo1HeatSetpt	nvo2HeatSetpt	nvo3HeatSetpt	nvo4HeatSetpt	nvo5HeatSetpt
Dehumidification humidity setpoint (P109)	nvo1DeshuSetpt	nvo2DeshuSetpt	nvo3DeshuSetpt	nvo4DeshuSetpt	nvo5DeshuSetpt
Humidification humidity setpoint (P115)	nvo1HumidSetpt	nvo2HumidSetpt	nvo3HumidSetpt	nvo4HumidSetpt	nvo5HumidSetpt
Supply air fan speed setpoint (P155)	nvo1FanSpeedCmd	nvo1FanSpeedCmd	nvo3FanSpeedCmd	nvo4FanSpeedCmd	nvo5FanSpeedCmd
Start-up request	nvo1DemMarche	nvo2DemMarche	nvo3DemMarche	nvo4DemMarche	nvo5DemMarche
On/Off	nvo1OnOff	nvo2OnOff	nvo3OnOff	nvo4OnOff	nvo5OnOff
Supply air fan (P330)	nvo1VentilSouf	nvo2VentilSouf	nvo3VentilSouf	nvo4VentilSouf	nvo5VentilSouf
Condensation unit 1 (P300)	nvo1GroupCond1	nvo2GroupCond1	nvo3GroupCond1	nvo4GroupCond1	nvo5GroupCond1
Condensation unit 2 (P304)	nvo1GroupCond2	nvo2GroupCond2	nvo3GroupCond2	nvo4GroupCond2	nvo5GroupCond2
Electric heater stage 1 (P320)	nvo1Eta1BatElec	nvo2Eta1BatElec	nvo3Eta1BatElec	nvo4Eta1BatElec	nvo5Eta1BatElec
Electric heater stage 2 (P322)	nvo1Eta2BatElec	nvo2Eta2BatElec	nvo3Eta2BatElec	nvo4Eta2BatElec	nvo5Eta2BatElec
Air flow rate ctrl percentage (P295)	nvo1PourDebitAir	nvo2PourDebitAir	nvo3PourDebitAir	nvo4PourDebitAir	nvo5PourDebitAir
Cooling coil ctrl percentage (P291)	nvo1PourBatFroid	nvo2PourBatFroid	nvo3PourBatFroid	nvo4PourBatFroid	nvo5PourBatFroid
Heating coil ctrl percentage (P290)	nvo1PourBatChaud	nvo2PourBatChaud	nvo3PourBatChaud	nvo4PourBatChaud	nvo5PourBatChaud
Electric heater ctrl percentage (P297)	nvo1PourBatElec	nvo2PourBatElec	nvo3PourBatElec	nvo4PourBatElec	nvo5PourBatElec
Humidifier ctrl percentage (P294)	nvo1PourHumidif	nvo2PourHumidif	nvo3PourHumidif	nvo4PourHumidif	nvo5PourHumidif
Fresh air ctrl percentage (P296)	nvo1PourAirNeuf	nvo2PourAirNeuf	nvo3PourAirNeuf	nvo4PourAirNeuf	nvo5PourAirNeuf
External safety (P278)	nvo1SecuExt	nvo2SecuExt	nvo3SecuExt	nvo4SecuExt	nvo5SecuExt
Non-critical fault summary (P352)	nvo1DefSimple	nvo2DefSimple	nvo3DefSimple	nvo4DefSimple	nvo5DefSimple
Critical fault summary (P350)	nvo1DefImportant	nvo2DefImportant	nvo3DefImportant	nvo4DefImportant	nvo5DefImportant
Supply air fan fault	nvo1DefVentilSouf	nvo2DefVentilSouf	nvo3DefVentilSouf	nvo4DefVentilSouf	nvo5DefVentilSouf
Air flow fault	nvo1DefDebitAir	nvo2DefDebitAir	nvo3DefDebitAir	nvo4DefDebitAir	nvo5DefDebitAir
Filter fouled fault	nvo1DefFiltreEnc	nvo2DefFiltreEnc	nvo3DefFiltreEnc	nvo4DefFiltreEnc	nvo5DefFiltreEnc
Clogged filter fault	nvo1DefFiltreBou	nvo2DefFiltreBou	nvo3DefFiltreBou	nvo4DefFiltreBou	nvo5DefFiltreBou
Electric heater fault	nvo1DefBatElec	nvo2DefBatElec	nvo3DefBatElec	nvo4DefBatElec	nvo5DefBatElec
Condensation unit 1 fault	nvo1DefGroupCon1	nvo2DefGroupCon1	nvo3DefGroupCon1	nvo4DefGroupCon1	nvo5DefGroupCon1
Condensation unit 2 fault	nvo1DefGroupCon2	nvo2DefGroupCon2	nvo3DefGroupCon2	nvo4DefGroupCon2	nvo5DefGroupCon2
Humidifier fault	nvo1DefHumidif	nvo2DefHumidif	nvo3DefHumidif	nvo4DefHumidif	nvo5DefHumidif
High temperature fault	nvo1DefTempHaut	nvo2DefTempHaut	nvo3DefTempHaut	nvo4DefTempHaut	nvo5DefTempHaut
Low temperature fault	nvo1DefTempBas	nvo2DefTempBas	nvo3DefTempBas	nvo4DefTempBas	nvo5DefTempBas
High humidity fault	nvo1DefHygroHaut	nvo2DefHygroHaut	nvo3DefHygroHaut	nvo4DefHygroHaut	nvo5DefHygroHaut
Low humidity fault	nvo1DefHygroBas	nvo2DefHygroBas	nvo3DefHygroBas	nvo4DefHygroBas	nvo5DefHygroBas
Water leak fault	nvo1DefFuiteEau	nvo2DefFuiteEau	nvo3DefFuiteEau	nvo4DefFuiteEau	nvo5DefFuiteEau
On/Off control	nvi1OnOffEnable	nvi2OnOffEnable	nvi3OnOffEnable	nvi4OnOffEnable	nvi5OnOffEnable
Cool temp. setpoint adjustment (P103)	nvi1CoolSetpt	nvi2CoolSetpt	nvi3CoolSetpt	nvi4CoolSetpt	nvi5CoolSetpt
Heating temp. setpoint adjustment (P104)	nvi1HeatSetpt	nvi2HeatSetpt	nvi3HeatSetpt	nvi4HeatSetpt	nvi5HeatSetpt
Dehumidification temperature setpoint adjustment (P109)	nvi1DeshuSetpt	nvi2DeshuSetpt	nvi3DeshuSetpt	nvi4DeshuSetpt	nvi5DeshuSetpt
Humidification temperature setpoint adjustment (P115)	nvi1HumidSetpt	nvi2HumidSetpt	nvi3HumidSetpt	nvi4HumidSetpt	nvi5HumidSetpt
Supply air fan speed setpoint adjustment (P155)	nvi1FanSpeedCmd	nvi2FanSpeedCmd	nvi3FanSpeedCmd	nvi4FanSpeedCmd	nvi5FanSpeedCmd



Order No.: EN7519369-00, 04.2017. Supersedes order No.
Manufacturer reserves the right to change any product specifications without notice.



Manufactured for France.
Printed in the European Union.